

Written-off light vehicle policies and procedures

August 2022

transport.nsw.gov.au

Table of Contents

About this document	4
Definitions	5
Overview	11
Purpose of this document	11
Written-off light vehicle law	11
Written-off light vehicles	11
Summary of written-off light vehicle processes	12
Total loss assessment process	13
Total loss assessment requirements.....	13
Statutory write-off assessment criteria	13
Notification process	15
Types and ages of notifiable light vehicles.....	15
Notification responsibilities.....	15
Authorised agents	15
How the WOLVR operates	15
Notification accuracy	16
Unauthorised disclosure of information.....	17
Access to information	17
Internet notifications	17
Information standards.....	18
Vehicle plan diagrams.....	23
Hail-damaged written-off light vehicles	25
Notifying hail-damaged written-off light vehicles.....	25
Warning labels	26
Label content.....	26

Transport
for NSW

Attaching labels26

Assessor records27

Record-keeping requirements.....27

Repair and registration process28

Eligibility for repair and registration28

Repair and registration process.....28

Repairing a written-off light vehicle.....28

Non-licensed repairer making repairs.....29

Using parts from a written-off light vehicle29

Receipts.....30

Certification process32

Certificate of Compliance.....32

Issuing a Certificate of Compliance32

Licensed repairer records..... 33

Record-keeping requirements.....33

Audit process34

Scheduled audits..... 34

Targeted audits..... 34

Audit and non-conformance reports..... 34

Record management expectations..... 34



About this document

This document describes the requirements for:

- Total loss assessment of light vehicles
- Notification of Written-off light vehicles to Transport for NSW (Transport) and data entry in the Written-off light vehicles register (WOLVR)
- Repairing Written-off light vehicles
- Issuing light vehicle Certificates of Compliance.

This document is accurate at the time of printing. For the latest information and electronic copies of this document visit the Transport website at roads-waterways.transport.nsw.gov.au

Written-off light vehicle requirements are detailed in the following legislation:

- [Road Transport Act 2013](#), and
- [Road Transport \(Vehicle Registration\) Regulation 2017](#).

To ensure you comply with your legal obligations, refer to this legislation on the NSW Legislation website at legislation.nsw.gov.au

Note: This document does not represent a comprehensive statement of the law. The information in this document is not a substitute for legal advice. You should seek independent legal advice if you need assistance on the application of the law to your situation.

Definitions

Australian Design Rules (ADRs)

The national standards under the [Motor Vehicle Standards Act](#) or the [Road Vehicle Standards Act 2018](#) of the Commonwealth, as in force from time to time.

Act

[Road Transport Act 2013](#)

Assessor

An Insurer, Self-insurer, Motor vehicle recycler, or Motor dealer.

Authorisation to Repair

An authorisation to repair a written-off light vehicle issued by Transport in accordance with the Act and Regulation.

Authorised officer

A police officer, or a person or class of persons specified by Transport, or Transport where the physical presence of an authorised officer is not required.

Certificate of Compliance

A light vehicle certificate of compliance issued by a Licensed repairer in accordance with the Act and Regulation.

Damage location

Locations of a vehicle which suffered damage. See [Vehicle damage locations](#).

GVM

Gross Vehicle Mass. For written-off vehicle purposes:

- the GVM recorded in the NSW vehicle registration database applies to vehicles registered in NSW or last registered in NSW, and
- the GVM recorded on the vehicle's identification plate or in the RAV applies to unmodified vehicles that have never been registered in Australia, or
- the highest GVM recorded on the vehicle's identification plate or in the RAV applies to unmodified vehicles with optional GVMs that have never been registered in Australia, or
- the new GVM recorded on the vehicle's modification plate (if applicable) or stated by a licensed certifier or an Approved Vehicle Examiner, applies to modified vehicles that have never been registered in Australia.

Hail-damaged written-off light vehicle

Light vehicles written-off solely due to hail damage and retained by the registered operator. See [Hail-damaged written-off light vehicles](#).

Note: Other hail-damaged vehicles that do not meet this definition are treated in the ordinary way.

Inspected written-off light vehicle

Previously written-off light vehicles which have since been repaired and registered.

Note: A Hail-damaged written-off light vehicle is taken to be an Inspected written-off light vehicle and is recorded in the WOLVR as such.

Insurer

A person who carries on the business of insuring vehicles.

Interstate written-off light vehicle

A vehicle recorded on a register of written-off vehicles of another Australian jurisdiction as either a statutory written-off light vehicle or a repairable written-off light vehicle, but only if that vehicle has not been registered in NSW or another jurisdiction since being recorded.

Licensed repairer

A person who holds a motor vehicle repairer's licence under the [Motor Dealers and Repairers Act 2013](#); or a person in another jurisdiction who holds, or employs a person who holds, the required national Vocational Education and Training qualifications set out in clause 36(1) of the [Motor Dealers and Repairers Regulation 2014](#) for the relevant class of repair work.

Light truck

An NB1 category vehicle:

- built on a rolling chassis, and
- where the cabin may be removed, and
- with the design and construction of a chassis-cab NC category vehicle.

In this definition NB1 category vehicle is a medium goods vehicle at clause 5.7, NC category vehicle is a heavy goods vehicle at clause 4.5.7, and chassis-cab has the same meaning at clause 3 of the [Vehicle Standard \(Australian Design Rule – Definitions and Vehicle Categories\) 2005](#) of the Commonwealth respectively.

This means that light trucks with a GVM of more than 3.5 tonnes and up to 4.5 tonnes are included. However, “utility” and “four-wheel drive passenger” type vehicles in this mass range are excluded.

Examples of Light trucks





Examples of vehicles that are not a Light truck





Market value

The price that the light vehicle would bring at open market, as determined (having regard to local market prices and the age and condition of the vehicle) by the Total loss assessor.

Motor bike

Motor bike includes a motor trike.

Motor dealer

Motor dealer has the same meaning as in the [*Motor Dealers and Repairers Act 2013*](#). That is, a person who carries on the business of dealing in motor vehicles as a retailer or on a wholesale basis.

Note: A person who carries on the business of assembling or manufacturing motor vehicles is not a motor dealer merely because the person sells any of those motor vehicles to a motor dealer or a financier. A financier is not a motor dealer. A motor vehicle broker is not a motor dealer. A person does not carry on the business of a motor dealer merely because the person sells a trailer for the conveyance of a second-hand boat sold by the person.

Motor vehicle recycler

Motor vehicle recycler has the same meaning as in the [*Motor Dealers and Repairers Act 2013*](#). That is, a person who carries on the business of buying or obtaining motor vehicles or parts or accessories of motor vehicles and demolishing or dismantling the motor vehicles or parts or accessories; and/or buying and selling the following parts or accessories of motor vehicles: chassis, major body section, bonnet, right side door (front), left side door (front), right side door (back), left side door (back), hatchback door, boot lid, right front guard, left front guard, front bumper bar, rear bumper bar, engine or engine block, gearbox, transmission or transaxle (front wheel drive vehicles), instrument cluster, odometer or hour gauge, car radio, tape or compact disc (CD) equipment, electronic navigation equipment, multimedia equipment, airbags and air curtains (side impact airbags), alloy wheels, seats, final drive (differential for rear wheel drive vehicles), headlights.

Notifiable light vehicle

A light vehicle is notifiable if it:

- complies (or complied at the time of manufacture) with the requirements of all ADRs adopted by the Regulation applying to it, and
- is a light vehicle, other than a Light truck, not more than 15 years old (age being determined from the date of manufacture [build date] to the date that the vehicle was assessed as a total loss by an

Assessor, or was sold by a Self-insurer to a Motor vehicle recycler, or a Motor vehicle recycler decided to demolish or dismantle the vehicle), or

- is a Light truck regardless of age, and
- is located anywhere in Australia but is linked to NSW because:
 - it is registered in NSW, or
 - it was last registered in NSW, or
 - it has never been registered in Australia, but one or more of the incidents that caused the vehicle to be assessed as a Total loss occurred in NSW.

Register of approved vehicles (RAV)

An online publicly searchable database of vehicles that have met the requirements of the [Road Vehicle Standards Act 2018](#) (RVSA) of the Commonwealth and been approved for provision to the Australian market.

Regulation

[Road Transport \(Vehicle Registration\) Regulation 2017](#)

Relevant technical specifications

The standards and methods of repair required to be met by a law of NSW for vehicles of that type, and:

- the standards and methods of repair documented by the manufacturer of vehicles of that type, to the extent that they are relevant to ensuring the structural integrity and safety of the vehicle, or
- where the manufacturer's documentation is unavailable, the standards and methods of repair recognised in the industry for vehicles of that type, to the extent that they are relevant to ensuring the structural integrity and safety of the vehicle.

RVSA

The [Road Vehicle Standards Act 2018](#) of the Commonwealth.

Salvage value

The value of a light vehicle if sold for scrap or parts, or in a damaged state, as determined by the Total loss assessor.

Secure Vehicle Identification (SVI)

A formal identification marking for new vehicles (and trailers) supplied to the market under the RVSA.

Self-insurer

A person who, in the course of a business, is the registered operator for five or more Notifiable light vehicles, or one or more Light trucks, which do not have insurance policies covering their loss or damage.

Statutory write-off assessment criteria

Damage that a Written-off light vehicle has suffered where the law directs Transport to not authorise repairs or re-register the vehicle. See [Statutory write-off assessment criteria](#).

Statutory written-off light vehicle

A vehicle that is recorded on the WOLVR as a Statutory written-off light vehicle.

Total loss

A vehicle that has been damaged, dismantled or demolished to the extent that its Salvage value as a Written-off light vehicle plus the cost of repairs would be more than its:

- Market value immediately before being damaged, dismantled or demolished, or
- the amount insured (if insured for a specific amount).

Total loss assessment

An assessment made by or on behalf of, and in the course of business of, an Assessor as to whether or not a Notifiable light vehicle is a Total loss.

Total loss assessor

A competent person who has the required training, qualification or experience to make a Total loss assessment for an Assessor.

Vehicle identifier

In the case of a light vehicle manufactured before January 1989, the number quoted on the compliance plate that uniquely identifies the vehicle and sets it apart from similar vehicles and that corresponds to the identification number of the vehicle that is permanently recorded elsewhere on the vehicle, or

In any other case, the unique Vehicle Identification Number (VIN) allocated to the vehicle in accordance with the International Standards Organisation's vehicle identification system required under an ADR adopted by the Regulation.

VIN

Vehicle Identification Number

Written-off light vehicles register (WOLVR)

The register of written-off light vehicles maintained by Transport in accordance with the Act and Regulation.

Written-off light vehicle

A light vehicle that has been assessed to be a Total loss, or that has been disposed of to a Motor vehicle recycler by a Self-insurer, or that will be demolished or dismantled by a Motor vehicle recycler.

Written-off light vehicle policies and procedures

This document is the *Written-off light vehicle policies and procedures* and applies to light vehicles.

Written-off light vehicle warning label

A label that must be attached to a Statutory written-off light vehicle. See [Warning labels](#).

Overview

Purpose of this document

The purpose of this document is to describe:

- Total loss assessment, notification, repair, certification and registration processes for Assessors and Licensed repairers under Written-off light vehicle law, and
- Transport expectations of Assessor and Licensed repairer compliance with their responsibilities under Written-off light vehicle law.

Written-off light vehicle law

The *Road Transport Act 2013* and the Road Transport (Vehicle Registration) Regulation 2017 provide for NSW's Written-off light vehicle law.

The law applies to Notifiable light vehicles. These are vehicles that comply with the ADRs and that are up to 4.5 tonnes Gross Vehicle Mass (GVM). For light vehicles other than Light trucks, they are up to 15 years old. For Light trucks they are of any age. See [Light truck](#).

The law requires Written-off light vehicles to be notified to Transport and recorded in the WOLVR.

Most light vehicles recorded in the WOLVR are classified as Statutory written-off light vehicles and their vehicle registration is cancelled. This means that the vehicle can only be used for parts or scrap. However, some light vehicles may be repaired and re-registered in limited circumstances if Transport issues an Authorisation to Repair. See [Eligibility for repair and registration](#).

Hail-damaged written-off light vehicles that are retained by the registered operator must still be notified to Transport and recorded in the WOLVR. They are classified as Inspected written-off light vehicles and the vehicle registration is not cancelled. See [Hail-damaged written-off light vehicles](#).

Written-off light vehicles

A Written-off light vehicle is a Notifiable light vehicle that:

- has been assessed as a Total loss by an Assessor, or
- has been disposed of to a Motor vehicle recycler by a Self-insurer, or
- has been demolished or dismantled by a Motor vehicle recycler, or
- is in the control of a Motor vehicle recycler and is intended to be demolished or dismantled, or
- has been recorded on the WOLVR.

Summary of written-off light vehicle processes

This diagram shows a high-level summary of Written-off light vehicle management processes detailed in this document.

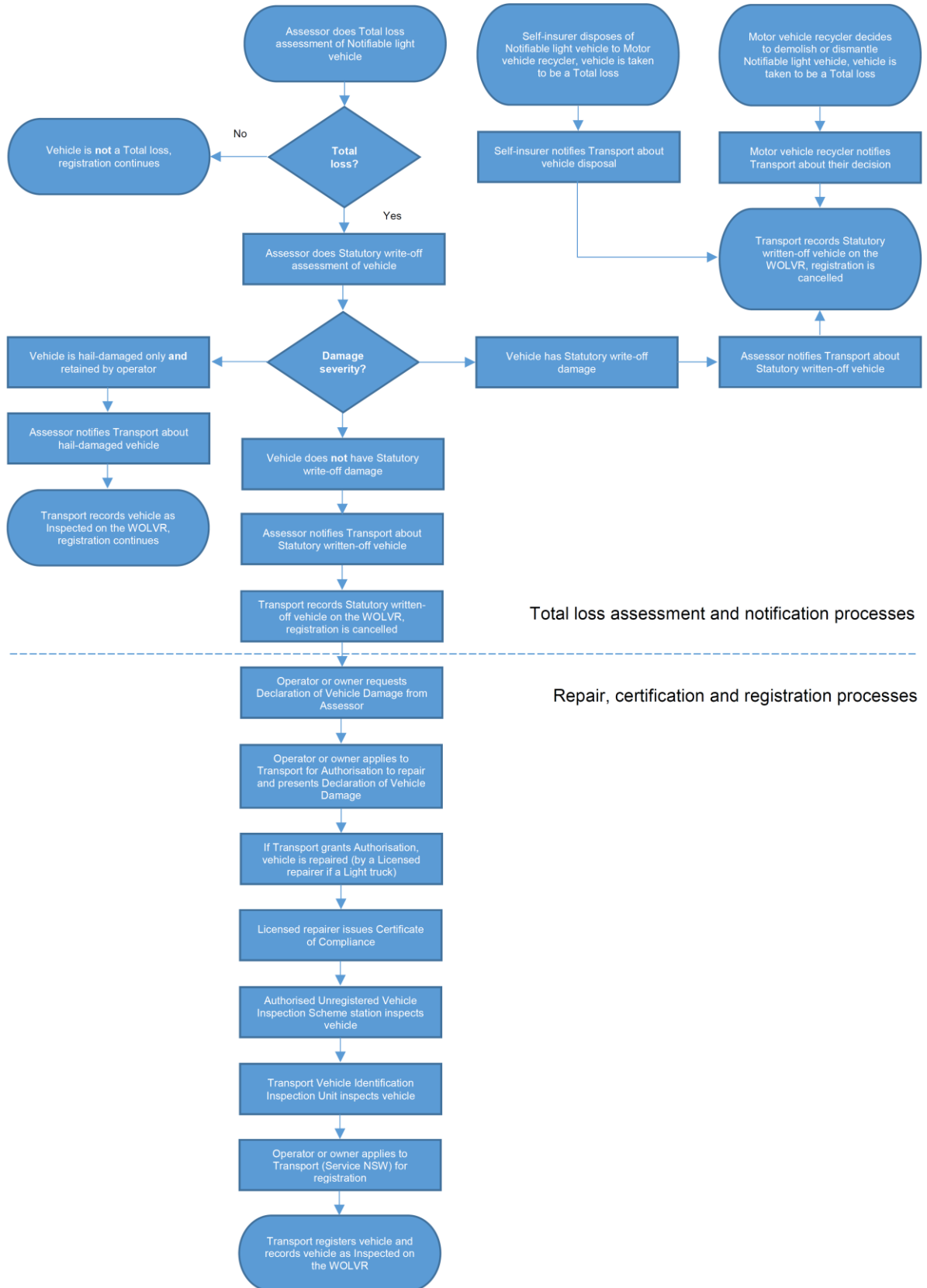

Total loss assessment process

Total loss assessment requirements

Assessed by a competent person

An Assessor must ensure that a Total loss assessment is made by a person (a Total loss assessor) who has all of the following training, qualifications, or experience:

- successful completion of an approved course*
- demonstrated ability to determine whether a vehicle has suffered damage specified in the Statutory write-off assessment criteria
- demonstrated ability to apply manufacturers' repair guidelines, recognised industry standards and the *Written-off light vehicle policies and procedures* (this document).

* **Note:** An approved course means a training course in vehicle repair assessment from a provider accredited by the Australian Skills Quality Authority, or a course that includes instruction on all of the following:

- obtaining and interpreting vehicle manufacturers' standards and methods of repair, and those recognised in the vehicle industry
- use of those standards and methods when calculating repair costs
- conducting repair assessments that comply with those standards and methods
- assessment of vehicle damage, taking into consideration the types of damage specified in the Statutory write-off assessment criteria.

Total loss assessment

An Assessor must ensure that a Total loss assessment:

- bases any calculation of the cost of repair of the vehicle on the Relevant technical specifications, and
- if the vehicle is a Total loss, includes an assessment of whether the vehicle has suffered damage specified in the Statutory write-off assessment criteria (see below).

Statutory write-off assessment criteria

Light vehicles that have been damaged to the extent that they have suffered damage specified in the Statutory write-off assessment criteria are not eligible for an Authorisation to Repair.

Vehicles other than Light trucks, motor bikes or light trailers

The [*Damage Assessment Criteria for the Classification of Light Vehicle Statutory Write-Offs*](#) published by Austroads sets out nationally agreed Statutory write-off assessment criteria for light vehicles other than Light trucks, motor bikes or light trailers.

Light trucks

The [*Damage Assessment Criteria for the Classification of Heavy Vehicle Statutory Write-Offs*](#) published by Austroads sets out nationally agreed Statutory write-off assessment criteria for Light trucks.

Note: The exemption for substantially stripped vehicles in the Austroads criteria does not apply in NSW.

Motor bikes

The Regulation sets out the following Statutory write-off assessment criteria for motor bikes:

- the motor bike has been burnt to such an extent that it is fit only for wrecking or scrap,
- the motor bike has been stripped of all, or a combination of most, exterior body parts, panels and components (for example the engine, wheels, and guards),
- the motor bike has impact damage (excluding scratching) to the suspension and two or more areas of structural frame damage,
- the motor bike has been fully immersed in salt water for any period, or in fresh water for more than 48 hours.

Light trailers

The Regulation sets out the following Statutory write-off assessment criteria for light trailers:

- the trailer has been burnt to such an extent that it is fit only for wrecking or scrap,
- the trailer has been stripped of all, or a combination of most, interior and exterior body parts, panels and components,
- the trailer has impact damage (excluding scratching) to the suspension and one or more areas of structural frame damage,
- for a trailer other than a skeleton-type trailer or box trailer, the trailer has been fully immersed in salt water for any period, or in fresh water for more than 48 hours.

Note: Skeleton-type trailer is a frame trailer that does not have a bottom or sides.

Notification process

Assessors must notify Transport about details of Written-off light vehicles and this information is recorded in the WOLVR.

Written-off light vehicle notifications can be submitted:

- online through a Business-to-Business interface that allows multiple vehicles to be notified in one transaction, or an internet user interface that allows pre-registered users to be guided through screens to notify one vehicle at a time. See [Internet notifications](#).
- by emailing a completed [Written-off Light Vehicle Notification \(Form 1584\)](#) to Transport. Assessors using this form must ensure that they provide correct, legible information, including a contact name and telephone number.

Types and ages of notifiable light vehicles

Vehicle type	Mass and age limit	Registration status
Light passenger or commercial vehicle	Up to 4.5 tonnes GVM and up to 15 years of age	A vehicle must be notified to the WOLVR if: <ul style="list-style-type: none"> • it is registered in NSW, or • it was last registered in NSW, or • it has never been registered in Australia but one or more of the incidents that caused the vehicle to be assessed as a Total loss occurred in NSW.
Light rigid truck	More than 3.5 tonnes and up to 4.5 tonnes GVM and no age limit	
Light prime mover	More than 3.5 tonnes and up to 4.5 tonnes GVM and no age limit	
Light trailer	Up to 4.5 tonnes GVM and up to 15 years of age	
Light caravan	Up to 4.5 tonnes GVM and up to 15 years of age	
Motor bike	Up to 15 years of age	

Notification responsibilities

Assessors must notify Transport about Notifiable light vehicles that they have assessed as a Total loss within seven days of that decision and before the vehicle is sold or otherwise disposed of. **Note:** The seven-day notification responsibility is **not** based on the settlement date.

Self-insurers must notify Transport about Notifiable light vehicles they dispose of to a Motor vehicle recycler within seven days after the vehicle is disposed of.

Motor vehicle recyclers must notify Transport about Notifiable light vehicles that they intend to demolish or dismantle within seven days of that decision.

Authorised agents

An Assessor may authorise an agent to notify relevant information to Transport.

In this case, the personal details of the agent and the Assessor must be provided to Transport.

The Assessor, not their agent, is guilty of an offence if a required notification is not given to Transport.

How the WOLVR operates

Written-off light vehicles notified to Transport are recorded as Statutory written-off light vehicles in the WOLVR.

Exceptions to this are vehicles written-off solely due to hail damage and the vehicle is retained by the registered operator. Hail-damaged written-off light vehicles are recorded in the WOLVR as Inspected written-off light vehicles and their vehicle registration is not cancelled.

The WOLVR is maintained by Transport in the same database that is used for vehicle registration and other purposes.

WOLVR notification requires standard vehicle identifiers that uniquely identify each vehicle, such as vehicle registration number, VIN, vehicle make and type.

These identifiers are compared against the vehicle registration records in the database to validate the data and confirm the correct vehicle (as notified).

If the vehicle identifiers match, the database is updated to:

- record the vehicle as a Statutory written-off light vehicle on the WOLVR and cancel the vehicle registration, or
- for Hail-damaged written-off light vehicles, record the vehicle as an Inspected written-off light vehicle on the WOLVR, and
- include the reasons why the vehicle was written-off, and
- record a condition on the vehicle record, and
- share the written-off vehicle details with other jurisdictions through the National Exchange of Vehicle and Driver Information System.

If the identifiers do not match, Transport notifies internet and batch interface users immediately through error messages, and contacts Assessors who email notifications. This allows details to be checked, corrected and re-entered as soon as possible.

Notification accuracy

Assessors are responsible for ensuring that all notifications to Transport about Written-off light vehicles are accurate, correct and complete.

The following are information accuracy requirements:

- The vehicle registration number must be transcribed directly from the number plates on the vehicle, unless there are no plates attached. In this case, the registration number must be transcribed from the Certificate of Registration (if available).
- The VIN must be transcribed directly from the vehicle or the VIN plate (not from the compliance plate or documentation). All characters are to be recorded.
- For vehicles with no compliance plate and a compliance date after 1 July 2022, information about the vehicle can be found on the SVI and RAV.
- If the VIN on the vehicle is not visible due to damage, complete the [Written-off Light and Heavy Vehicles Register Advice Identification Discrepancy \(Form 5574\)](#) to obtain advice.
- If the VIN recorded on the Certificate of Registration does not match the one on the vehicle, complete the [Written-off Light and Heavy Vehicles Register Advice Identification Discrepancy \(Form 5574\)](#) to arrange a data fix.
- If a notification is not provided accurately, complete the [Written-off Light and Heavy Vehicles Register Advice Identification Amendment \(Form 5572\)](#) to correct the details.
- If the wrong vehicle is notified, complete the [Written-off Light and Heavy Vehicles Register Advice Identification Amendment \(Form 5572\)](#) to reverse the notification.

Unauthorised disclosure of information

Information obtained in connection with the administration of Written-off light vehicles must not be disclosed, unless it is for a purpose allowed by law.

Significant penalties apply for the unauthorised disclosure of Written-off light vehicle information.

Access to information

General queries to check if a vehicle has been recorded as written-off can be made to Service NSW on **13 77 88** or at service.nsw.gov.au

Internet notifications

Obtaining access to the system

Complete the [Written-off Vehicle Register \(WOVR\) - Internet Access \(Form 1163\)](#).

If approved by Transport, Assessors will have two types of system users: Security Administrator and General User.

Security Administrator

Security Administrators can make an enquiry, display information, enter and transmit details of Written-off light vehicles in the WOLVR.

One or more Security Administrators can be appointed for each Assessor.

Security Administrators are responsible for contacting Transport about the management of General Users. For example, they may request access for a new user (using the application form above).

They are also responsible for notifying changes to authorised users and ensuring the general security of access to WOLVR information. See [Business security measures](#).

General User

General Users can enter and transmit details of Written-off light vehicles in the WOLVR. General users who are an insurer can also make an enquiry and display information on existing write-offs.

Internet WOLVR usage

When accessing the system, Assessors must:

- accept the Terms and Conditions
- ensure that personal user identification codes (user IDs) and passwords are securely maintained
- ensure that work practices do not allow opportunities for unauthorised use of the WOLVR
- enter information about specific Written-off light vehicles according to the requirements of the Written-off light vehicles law and the *Written-off light vehicle policies and procedures* (this document)
- if there is a change of Security Administrator or User, immediately notify Transport by completing [Written-off Vehicle Register \(WOVR\) - Internet Access \(Form 1163\)](#).

Business security measures

Organisations using the system are responsible for ensuring that their work practices do not allow opportunities for unauthorised use of the WOLVR.

Significant penalties apply for the unauthorised use of the WOLVR.

Access to the WOLVR must only be available in controlled conditions, to minimise the risk of corrupt practices.

To perform WOLVR notifications, system users must be directly and permanently employed or working under contract for an organisation.

System users are allocated user IDs and passwords by Transport. Users reset their own passwords when logging in for the first time.

Users must ensure that their login details are not available to or used by any other person and must log out if leaving their computer unattended.

Information from the WOLVR must not be available to unauthorised personnel.

Internet transmission security

The system incorporates the following security measures:

- Data encryption and compression.
- The user ID is included in each transaction.
- If a screen within the WOLVR is left unattended for 45 minutes the user will be locked out of the WOLVR. Once locked out, a user must reconnect to the Transport web server.
- Invalid attempts to log into the WOLVR are recorded and an alarm is triggered when repeated unsuccessful attempts are made.
- After a specified number of attempts the user will be locked out of the system.

Internet access issues

For internet access issues, call the Transport DRIVES Help Desk on **1300 131 172**.

Information standards

The following fields are available when notifying Transport about Written-off light vehicles in the system. Field data entry is mandatory or optional, or data is displayed, depending on the situation.

Field name	Description	Data entry
Additional details	In cases where a vehicle is involved in more than one incident, the first incident should be recorded in the "Incident type" field, and the second or subsequent incidents should be recorded in this free form text field of 60 characters.	Optional
Chassis number	The chassis number is entered for vehicles manufactured before 1 January 1989.	Mandatory (for pre-1989 vehicles)
Compliance date	A reference to the vehicle's date of compliance to confirm that the Assessor and Transport are exchanging information about the same vehicle.	Display
Damage locations	Indicates the location(s) for all damage to the vehicle according to a range of codes (numbered 1 to 46) that represent locations on various vehicle types. See Vehicle damage locations .	Mandatory

Transport
for NSW

Damage severity codes	Indicates the extent to which a vehicle is damaged. The severity damage descriptions vary according to the type of incident that has been recorded for each vehicle. See Vehicle damage severity .	Mandatory
Date written-off	Enter the date that the vehicle was assessed as a total loss by an Assessor or was sold by a Self-insurer to a Motor vehicle recycler, or a Motor vehicle recycler decided to demolish or dismantle the vehicle.	Mandatory
Engine number	A reference to the vehicle's engine number (if applicable) to confirm that the Assessor and Transport are exchanging information about the same vehicle.	Display
Incident type	Indicates the circumstances that resulted in the vehicle being written-off. Incident type codes: <ul style="list-style-type: none"> ● Fire (F) ● Hail (H) ● Impact (I) ● Malicious (M) ● Water damage (W) ● Dismantled (D) 	Mandatory
Notified by	Identifies the organisation who is notifying Transport about the written-off vehicle.	Display
Notifier's reference number	Enter the notifier's reference number, if applicable.	Optional
Plate number	The vehicle plate number is entered. The vehicle plate number complements the VIN or chassis number.	Mandatory (if the Vehicle ID is not entered)
Salvage condition	Identifies the condition of the vehicle after the incident, as assessed by the Assessor. Salvage condition codes: <ul style="list-style-type: none"> ● Statutory W/O (X), or ● Hail (H) 	Mandatory
Vehicle description	A reference to the vehicle's make and model to confirm that the Assessor and Transport are exchanging information about the same vehicle.	Display
Vehicle ID	The vehicle identification number recorded in the Transport vehicle registration database. The vehicle ID can be entered if the vehicle plate number is not known.	Mandatory (if the Plate number is not entered)
Vehicle type	Used to define which combinations of damage criteria can apply to the selected vehicle type. Vehicle type code: <ul style="list-style-type: none"> ● Light passenger or commercial vehicle (V) ● Light rigid truck (I) ● Light prime mover (Q) ● Light trailer (T) ● Light caravan (C) ● Motor bike (M) 	Mandatory
VIN	The Vehicle Identification Number (VIN) is entered for vehicles manufactured on or after 1 January 1989.	Mandatory (for post-1988 vehicles)

Vehicle damage locations

This information identifies locations of a vehicle which have suffered damage.

Damage Location		Vehicle Type			
Code	Description	V	I	T	M

			Light passenger or commercial vehicle	Light rigid truck Q Light prime mover	Light trailer C Light caravan	Motor bike
01	PASSENGER FRONT	Left side panels and glass - panels or glass	✓	✓		
02	DRIVER FRONT	Right side panels and glass - panels or glass	✓	✓		
03	DRIVER SIDE	Panels and glass or panels or glass	✓	✓		
04	DRIVER REAR	Right side panels and glass - panels or glass	✓	✓		
05	PASSENGER REAR	Left side panels and glass - panels or glass	✓	✓		
06	PASSENGER SIDE	Panels and glass - panels or glass	✓	✓		
07	ENGINE	Coverage includes within the engine bay and mechanical or electrical components	✓	✓		
08	ROOF	Upper covering of a vehicle which is supported by the structure	✓	✓		
09	INTERIOR	Coverage includes from the floor pan to the roof	✓	✓		
10	FRONT	Portion of the frame			✓	✓
11	REAR	Portion of the frame			✓	
12	LEFT REAR	Portion of the frame and other components				✓
13	RIGHT REAR	Portion of the frame and other components				✓
14	WHOLE VEHICLE	Majority of vehicle exterior has been damaged or affected by fire or water	✓	✓		
15	FLOOR PAN (PASSENGER FRONT)	Left side front panel at passengers' feet	✓	✓		
16	FIRE WALL	The panel dividing passenger compartment from the vehicle's engine	✓	✓		
17	CHASSIS/STRUCTURAL RAILS (PASSENGER)	Left side longitudinal body and suspension support beam	✓	✓		

Transport
for NSW

18	FLOOR PAN (DRIVER REAR)	Right side rear of panel	✓	✓		
19	FLOOR PAN (DRIVER FRONT)	Right side front of panel separating passengers' compartment from vehicles underbody	✓	✓		
20	FLOOR PAN (PASSENGER REAR)	Left side rear of panel separating passengers' compartment from vehicles underbody	✓	✓		
21	CHASSIS/STRUCTURAL RAILS (DRIVER)	Right side longitudinal body and suspension support beam	✓	✓		
22	A PILLAR PASSENGER	Left side windscreen support pillar	✓	✓		
23	A PILLAR DRIVER	Right side windscreen support pillar	✓	✓		
24	B PILLAR PASSENGER	Left side turret support pillar	✓	✓		
25	B PILLAR DRIVER	Right side turret support pillar	✓	✓		
26	C PILLAR PASSENGER	Left side turret support pillar	✓	✓		
27	C PILLAR DRIVER	Right side turret support pillar	✓	✓		
28	D PILLAR PASSENGER	Left side turret support pillar	✓	✓		
29	D PILLAR DRIVER	Right side turret support pillar	✓	✓		
30	ENGINE BLOCK (CRACKED, FRACTURED)	Engine crankcase damaged by impact, fire, water	✓	✓		
31	TRANSMISSION CASE	Gearbox or transfer case cracked or fractured	✓	✓		
32	DIFFERENTIAL CASE	Front or rear differential is fractured or cracked	✓	✓		
33	AXLE HOUSING	Front or rear axle housings cracked or fractured	✓	✓		
34	SUSPENSION (PASSENGER FRONT)	Any part of left front suspension member is damaged or bent	✓	✓		
35	SUSPENSION (DRIVER FRONT)	Any part of right front suspension member is damaged or bent	✓	✓		
36	SUSPENSION (PASSENGER REAR)	Any part of left rear suspension member is damaged or bent	✓	✓		

OFFICIAL

37	SUSPENSION (DRIVER REAR)	Any part of right rear suspension member is damaged or bent	✓	✓		
38	AIRBAG FRONT	Driver or passenger front air bag has deployed	✓	✓		
39	AIRBAG SIDE	Right or left side air bag has deployed	✓	✓		
40	AIRBAG CURTAIN	Right or left side curtain airbag has deployed	✓	✓		
41	SEAT BELT PRE-TENSIONER	Drivers front or rear seat belt pre-tensioners has deployed	✓	✓		
42	BATTERY PACK	For electric vehicles		✓		
43	TOW POINT	Fifth wheel, turntable, king pin, drawer bar, hook, eyelet, etc.		✓		
44	AUXILIARY EQUIPMENT	Crane, concrete pump or mixer, tank, pump, garbage compactor, etc.		✓		
45	HYDRAULIC OR OTHER LIFTING EQUIPMENT	Ram on a tipping trailer, etc.		✓		
46	ROLLOVER PROTECTIVE STRUCTURE	Bus rollover protective structure				

Vehicle damage severity

This information identifies the extent of the vehicle's damage. Several damage severity codes can be selected when needed. For example, select "Heavy panel" for impact damage and "Water (fresh)" for fresh water immersion.

Code	Damage severity	Description
A	Heavy panel	Replace panel
B	Light panel	Repairable, traditional or paintless
C	Heavy structural	Replace structural part
D	Light structural	Repair structural part
E	Unrepairable	Physical or economic
F	Major damage	Engine, transmission driveline, suspension component or damage to the interior requires replacement
G	Minor damage	Engine, transmission driveline, suspension component or damage to the interior requires repair or replacement
H	Major stripping	Interior parts, external panels
I	Minor stripping	Wheels, radio, damaged door locks etc.
J	Major vandalism	Interior parts, external panels
K	Minor vandalism	Wheels, radio, damaged door locks etc.

L	Water (salt)	Internal cabin of the vehicle has been inundated with salt water to a level above the inner door sill for any period, or for a motor bike fully immersed for any period
M	Water (fresh)	Internal cabin of the vehicle has been inundated with fresh water to a level above the inner door sill for any period, or for a motor bike fully immersed for any period
N	Burnt / blistered	More than one third of the vehicle completely burnt, or burnt to the extent that repairs are not economic
O	Smoke and heat	Minor engine fire or minor interior fire or exterior exposed to external heat source
P	Minor smoke	Smoke / soot damage to the interior of the vehicle

Vehicle plan diagrams

Light passenger or commercial vehicle

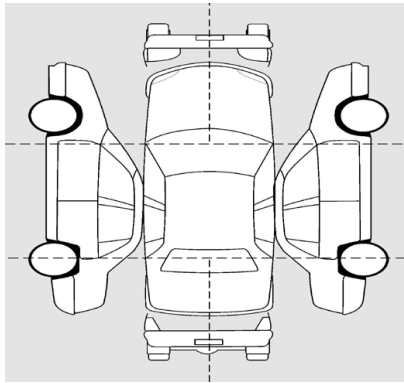

Light rigid truck

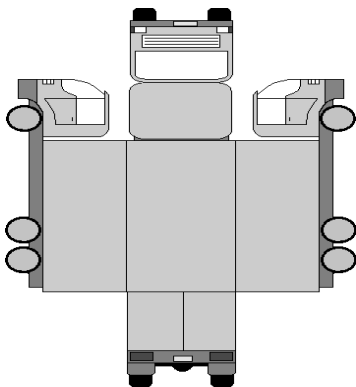

Light prime mover

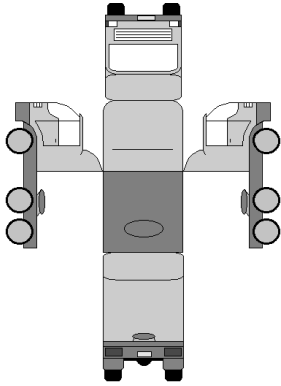

Light trailer or light caravan

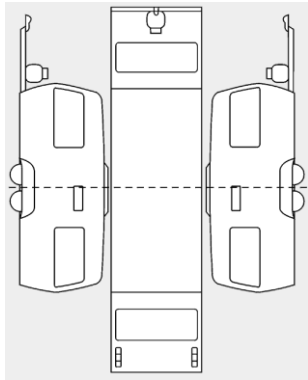

Motor bike

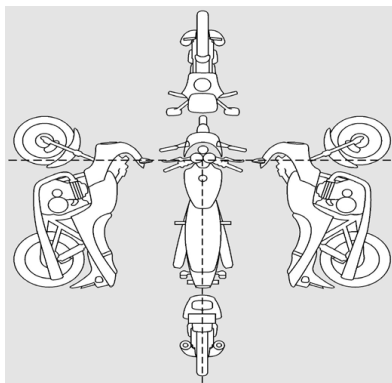

Hail-damaged written-off light vehicles

Hail-damaged written-off light vehicles are treated differently to other types of Written-off light vehicles.

A Hail-damaged written-off light vehicle is a Notifiable vehicle that:

- has been assessed as a Total loss by an Assessor, and
- only has hail damage, and
- is retained by the registered operator.

Notifying hail-damaged written-off light vehicles

Assessors must notify Transport about Hail-damaged written-off light vehicles. Salvage condition code “Hail (H)” and the incident type code “Hail (H)” must be selected when notifying Transport about the vehicle.

Unlike other Written-off light vehicles, the vehicle registration is not cancelled when the vehicle is recorded in the WOLVR. Any subsequent Certificate of Registration issued for the vehicle states “vehicle is recorded on the register of written-off vehicles” for consumer information.

Note: If the vehicle also has damage other than hail damage, or if the vehicle is not retained by the registered operator, it is not a Hail-damaged written-off light vehicle. In this case, the salvage condition code “Statutory W/O (X)” must be selected and the vehicle registration is cancelled.

Warning labels

Written-off light vehicle warning labels must be attached to all Written-off light vehicles.

Significant penalties apply for the unauthorised alteration, damage, destruction, removal or interference of warning labels.

Label content

Warning labels must include the statement “**Statutory written-off light vehicle – available for parts or scrap only – limited exemptions apply.**”

Attaching labels

Warning labels must be attached securely to the vehicle in a conspicuous position where anyone looking at the vehicle might be expected to see it, and it does not obscure the vehicle identifier.

For a dismantled vehicle, the warning label must be attached to the part that has the vehicle identifier.

Warning labels must be attached within the same seven-day period in which Transport must be notified about Written-off light vehicles. See [Notification responsibilities](#).

An Assessor may authorise an agent to attach a warning label. The Assessor, not their agent, is guilty of an offence if a warning label is not attached as required.

Assessor records

Assessors must maintain records for all Total loss assessments of Notifiable light vehicles, regardless if the vehicle is determined to be a Total loss or not.

Total loss assessment records must be kept by Assessors for a period of at least seven years and produced to an Authorised officer if directed.

Significant penalties apply for not keeping or producing required records.

Record-keeping requirements

Total loss assessment records must contain sufficient information to substantiate the assessment decision, including:

- Vehicle identification details:
 - whether the vehicle is a light passenger or commercial vehicle, light rigid truck, light prime mover, light trailer, light caravan or motor bike
 - registration number
 - vehicle identifier (VIN)
 - make and model
 - shape
 - colour
 - variant
 - date of manufacture
 - engine capacity
 - number of cylinders
 - motive power
 - tare weight
- Assessment details:
 - whether the damage to the vehicle was caused by hail, water, impact, fire or stripping, and
 - the location and severity of the damage to the vehicle, and
 - details of the determination on whether or not the vehicle has suffered damage specified in the Statutory write-off assessment criteria, and
 - date on which the determination was made.
- Details of the Total loss assessor:
 - name and address
 - telephone and fax number (unless these are provided to Transport electronically)
 - Transport customer number, or if they don't have one, their driver licence number.
- Reasons why the Total loss assessor was competent to do the Total loss assessment.
- Sum for which the vehicle was insured or the Market value of the vehicle and how that value was calculated.
- Assessed cost of repairs and details of how the cost was determined, including application of the Relevant technical specifications.
- The assessed Salvage value of the vehicle and the basis for determining that value.

Repair and registration process

Eligibility for repair and registration

Certain Written-off light vehicles may be eligible for repair and re-registration. Before a Written-off light vehicle may be repaired and registered, the vehicle operator must obtain an Authorisation to Repair from Transport.

Transport will only consider an application for an Authorisation to Repair in the following limited circumstances:

- the vehicle has **not** suffered damage specified in the [Statutory write-off assessment criteria](#), and
- the applicant is the same registered operator and the vehicle only has hail damage (where [Hail-damaged written-off light vehicles](#) does not apply), or
- the applicant was the registered operator for more than 28 days before the vehicle was damaged, or
- the applicant inherited the vehicle from the registered operator.

Repair and registration process

1. The vehicle operator or owner requests a completed [Declaration of Vehicle Damage \(Form 5681\)](#) from the Assessor.
2. The vehicle operator or owner sends a completed [Application to repair a written-off light vehicle \(Form 1585\)](#) to Transport with the [Declaration of Vehicle Damage \(Form 5681\)](#) that was completed by the Assessor.
3. If Transport issues an Authorisation to Repair:
 - the damage affecting the vehicle's structural integrity and safety must be repaired according to manufacturer's guidelines (or to recognised industry standards if there are no manufacturer's guidelines). **Note:** Light trucks can only be repaired by a Licensed repairer. See [Light truck](#), and
 - a Licensed repairer holding an appropriate class of licence issued by NSW Fair Trading (or the required qualifications if interstate) must issue a Certificate of Compliance ([Light passenger or commercial vehicle \(Form 1588\)](#), [Light rigid truck \(Form 5684\)](#), [Light prime mover \(Form 5685\)](#), [Light trailer or caravan \(Form 1590\)](#) or [Motor bike \(Form 1589\)](#)), certifying that the repairs to damage affecting the vehicle's structural integrity and safety have been carried out to recognised standards. See [Certification process](#).
4. The vehicle must pass an Authorised Unregistered Vehicle Inspection Scheme (AUVIS) inspection.
5. The vehicle must pass an inspection by the Transport Vehicle Identification Inspection Unit.
6. The vehicle operator or owner can apply to Transport to register the vehicle.
7. When the vehicle is registered, its status is changed to Inspected written-off light vehicle on the WOLVR.

Repairing a written-off light vehicle

Motor vehicles are required to comply with the applicable ADRs current at the time of manufacture. There are now over 80 ADRs which apply to the design and construction of a vehicle. A number of these ADRs can be affected when a vehicle

is repaired after being damaged.

Vehicle manufacturers are continually improving the design and construction of motor vehicles, and repairers must be aware of:

- the types of materials used in the construction, and
- any particular repair processes specified by the vehicle manufacturer.

Therefore, when repairing a vehicle, the operator (and in the case of a Light truck, the Licensed repairer) must be aware of:

- the effects the repair could have on the overall safety of the vehicle, and
- its compliance with the ADRs, and
- taking all necessary steps to return the vehicle to at least a compliant pre-damage level of structural integrity and safety.

Non-licensed repairer making repairs

If a person other than a Licensed repairer repairs a Written-off light vehicle for the purpose of registration in NSW, they still must repair any damage affecting the vehicle's structural integrity and safety according to manufacturer's guidelines (or to recognised industry standards if there are no manufacturer's guidelines).

Transport recommends vehicle operators consult with a Licensed repairer before starting repairs, to ensure certification goes smoothly. Licensed repairers may need vehicle operators to:

- allow them to do a series of inspections at key points during the repair process
- keep a repair diary that describes the repair process
- take photographs of the damaged areas before and after repairs
- keep copies of the pages of relevant standards referred to during repairs, and
- meet other possible requirements.

Note: Light trucks can only be repaired by a Licensed repairer. See [Light truck](#).

Using parts from a written-off light vehicle

Salvaged parts used to repair a written-off light vehicle

Some non-structural bolt on body parts (for example, guards, panels) salvaged from a Written-off light vehicle can be used to repair another Written-off light vehicle, as shown in the following table:

Parts (all vehicle types)	Salt water damage	Fresh water damage	Fire	Collision
Mudguards	YES	YES	*	*
Bonnet	YES	YES	*	*
Doors	NO	NO	*	*
Skirt rail sections	NO	NO	*	*
Front sections (including front (A) pillar, sill and floor sections)	NO	NO	*	*
Rear sections (including rear (C) pillar, sill and floor sections)	NO	NO	*	*
Roof cut sections (including centre pillar)	NO	NO	*	*
Engine cross member	NO	NO	*	*

OFFICIAL

Seat belts	NO	NO	NO	NO
Airbags	NO	NO	NO	NO
Airbag modules	NO	NO	NO	NO
Seat belt pre-tensioners	NO	NO	NO	NO
Steering column	NO	NO	*	*
Suspensions	YES	YES	*	*
Interior / trims	YES	YES	*	*
Seat frames/metal components	NO	NO	*	*
Wiring looms	NO	NO	NO	*
Instrument clusters and dash controls	NO	NO	NO	NO
Control modules and SRS sensors	NO	NO	NO	NO
Engine	YES	YES	YES	YES
Chassis	NO	YES	NO	*

*** Note:**

- only parts unaffected by fire or collision are suitable for use in a repair
- the Licensed repairer or Transport may reject parts deemed not suitable
- photographic evidence may be required to support that the part is suitable.

Mechanical components

Steering boxes and similar mechanical components for all light vehicles must be closely inspected for damage and appropriately tested before installation.

Sectionalised repairs

Sectionalised repair of a Written-off light vehicle is permitted when done according to manufacturer's guidelines or recognised industry standards.

The section used should be:

- a new section supplied as a service assembly by the vehicle manufacturer, or
- a suitable assembly removed from a new body shell as supplied by a vehicle manufacturer, or
- a suitable undamaged section salvaged from another vehicle of the same make, model and variant.

The salvaged section must be in a sound and generally undamaged condition with no previous major repairs which could affect the strength of the basic structure.

Monocoque vehicles

A monocoque bodyshell cannot be rebodied or repaired with a new bodyshell.

However, it can be repaired using replacement sections, provided original factory joints and welds are used.

Receipts

Receipts must be kept for any parts purchased during the repair process. The vehicle operator will need to present these to the Transport Vehicle Identification Inspection Unit when the vehicle is inspected. The Licensed repairer who certifies the repairs may ask to view and make copies of these receipts.

Receipts must be original documents and include:

Transport
for NSW

- company name and ABN (if supplied by a business)
- name and address of the seller (if supplied by a non-business)
- name and address of the buyer
- clear and legible description of the parts
- vehicle identifier of the source vehicle (if sourced from another vehicle)
- date of sale.

Note: Transport recommends vehicle operators keep **all** information about the repair process in case it is needed by the Licensed repairer or Transport.

Certification process

Only a Licensed repairer can certify repairs to a Written-off light vehicle for the purpose of registration in NSW.

Written-off light vehicles do not have to be repaired by a Licensed repairer unless the vehicle is a Light truck. See [Light truck](#).

Transport recommends vehicle operators consult with a Licensed repairer before starting repairs, to ensure certification goes smoothly. Licensed repairers may need vehicle operators to meet certain requirements to allow a Certificate of Compliance to be issued. See [Non-licensed repairer making repairs](#).

Licensed repairers may certify their own repairs.

Certificate of Compliance

The Certificate of Compliance ([Light passenger or commercial vehicle \(Form 1588\)](#), [Light rigid truck \(Form 5684\)](#), [Light prime mover \(Form 5685\)](#), [Light trailer or caravan \(Form 1590\)](#) or [Motor bike \(Form 1589\)](#)) is completed by a Licensed repairer holding an appropriate class of licence issued by NSW Fair Trading (or the required qualifications if interstate).

The certificate contains a declaration that any damage affecting the vehicle's structural integrity and safety has been repaired according to manufacturer's guidelines or to recognised industry standards.

A Certificate of Compliance is valid for three months from the date of issue, unless otherwise approved by Transport.

Issuing a Certificate of Compliance

To issue a Certificate of Compliance, a Licensed repairer must:

- Hold an appropriate class of licence issued by NSW Fair Trading (or the required qualifications if interstate).
- Be satisfied that any damage affecting the structural integrity and safety of the vehicle is repaired according to manufacturer's guidelines (or to recognised industry standards if there are no manufacturer's guidelines), and the *Written-off light vehicle policies and procedures* (this document).
- For a Light truck, be satisfied that any damage affecting the structural integrity and safety of the vehicle was repaired by a Licensed repairer.
- Where structural damage has occurred, arrange a test report on the repaired vehicle's structural integrity.
- Where electronic control systems (such as airbags or Anti-lock Braking Systems) have been repaired, arrange certification from a Licensed repairer authorised by the vehicle manufacturer or Transport.
- Complete the Certificate of Compliance.
- Attach copies of the relevant pages of standards to which the vehicle was repaired to the Certificate of Compliance.

Licensed repairer records

Licensed repairers must maintain records for each light vehicle they examine for the purpose of determining whether or not to issue a Certificate of Compliance.

Certification records must be kept by Licensed repairers for a period of at least seven years and produced to an Authorised officer if directed.

Significant penalties apply for not keeping or producing required records.

Record-keeping requirements

Licensed repairers must keep the following certification records for each light vehicle they examine:

- Vehicle identification details, including:
 - whether the vehicle is a light passenger or commercial vehicle, light rigid truck, light prime mover, light trailer, light caravan or motor bike
 - registration number
 - vehicle identifier (VIN)
 - make and model
 - shape
 - colour
 - variant
 - date of manufacture
 - engine capacity
 - number of cylinders
 - motive power
 - tare weight
- Reference number of Transport Authorisation to Repair
- Details of the repair assessment, including:
 - repair inspection dates
 - repairs inspected
 - photographs of repairs (if the repairs were not done by the Licensed repairer)
 - how repairs were conducted
- Details of how any damage affecting the structural integrity and safety of the vehicle was repaired according to manufacturer's guidelines (or to recognised industry standards if there are no manufacturer's guidelines), and the *Written-off light vehicle policies and procedures* (this document)
- If the repair involved structural damage, the test report on the repaired vehicle's structural integrity
- Copies of receipts if repaired by the vehicle operator or owner
- Where electronic control systems (such as airbags or Anti-lock Braking Systems) have been repaired, the certification from a Licensed repairer authorised by the vehicle manufacturer or Transport
- Basis on which the decision to issue a Certificate of Compliance was made
- Date the certificate was issued.

Audit process

Transport does schedule and targeted audits of Assessors and Licensed repairers' compliance with their responsibilities under Written-of light vehicle law, and the *Written-off light vehicle policies and procedures* (this document).

Scheduled audits

Transport gives Assessors and Licensed repairers a minimum of four weeks' notice. Two Transport Authorised officers conduct the audit and a formal audit report is provided within 10 days of completion of the audit.

The audit process has four steps:

1 Entry meeting

This meeting is convened by the Transport Authorised officers and provides details of the audit process, requirements and audit tool. Where previous audits have been done and corrective actions identified, the Transport Authorised officers request information from the Assessor or Licensed repairer about the actions taken.

2 Document review

The Transport Authorised officers review documentation requested by Transport to assess compliance with the law, policies and procedures. See [Record management expectations](#).

3 Questions arising from the document review

This meeting is held between the Transport Authorised officers and Assessor or Licensed repairer representatives to clarify any items identified during the document review.

4 Exit meeting

This meeting provides feedback from the audit but not the final result or audit report.

Targeted audits

These audits are not pre-notified but follow the scheduled audit process detailed above.

Audit and non-conformance reports

Transport provides Assessors and Licensed repairers an audit report within 10 days of completing the audit. The report details the audit outcomes and any corrective actions identified. Where corrective actions are required, Transport issues the Assessor or Licensed repairer a notice detailing the required action and timeframe for correction.

Record management expectations

Assessors and Licensed repairers should manage their assessment and certification records in a systematic manner. Transport Authorised officers examine these records to ensure compliance with the law, policies and

procedures. Transport record management expectations are:

For Assessors and Licensed repairers:

- Records are established in standardised order (standard set by the Assessor or Licensed repairer) that includes easy access to the VIN.
- Records are stored securely.
- Evidence of current documentation being available for use by Total loss assessors and Licensed repairers, including:
 - endorsed work processes
 - Statutory write-off assessment criteria
 - manufacturers and industry recognised repair guidelines
 - *Written-off light vehicle policies and procedures* (this document).

For Assessors:

- Reasons for Total loss assessment decisions and Statutory write-off assessment criteria decisions documented and justified.
- Training records of Total loss assessors are current and available for review.
- Standardised process in place for the professional development of Total loss assessors and for the review of their competency against required standards.
- Copies of all notifications to the vehicle operator or owner, and Transport, about the vehicle's assessment, including any **Declaration of Vehicle Damage (Form 5681)** issued, are to be retained on file.

For Licensed repairers:

- Reasons for the decision to issue Certificates of Compliance documented and justified.
- Reference number of Transport Authorisations to Repair documented.
- Appropriate class of motor vehicle repairer's licence issued by NSW Fair Trading (or the required qualifications if interstate) held and retained on file.
- Vehicle structural integrity test reports retained on file.
- Copies of receipts if repaired by the vehicle owner.
- Copies of all notifications to the vehicle operator or owner, and Transport, about the vehicle's certification examination, including any Certificate of Compliance (**Light passenger or commercial vehicle (Form 1588)**, **Light rigid truck (Form 5684)**, **Light prime mover (Form 5685)**, **Light trailer or caravan (Form 1590)** or **Motor bike (Form 1589)**) issued, are to be retained on file.

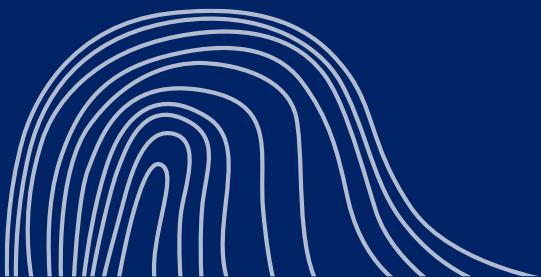

© Transport for New South Wales

Users are welcome to copy, reproduce and distribute the information contained in this report for non-commercial purposes only, provided acknowledgement is given to Transport for NSW as the source.