

Project Remediate

Cladding Replacement Pattern Book



Foreword

Replacing flammable cladding on high-risk, residential apartment buildings presents a complex and challenging situation for unit owners.

Creating a robust and enduring remediation solution is not just simply about replacing one façade with another. It requires a combination of expert remediation design and safe, suitable cladding materials and systems applied by qualified and experienced designers and contractors.

Project Remediate was created to proactively respond to the challenge of replacing these materials with safe, durable and compliant remediation solutions for over 200 eligible buildings across NSW. It supports affected owners' corporations throughout their remediation journey and leaves them with a building that has no flammable cladding legacy.

The Cladding Product Safety Panel plays an important role in providing independent, expert advice to inform the cladding replacement work carried out under Project Remediate. The Panel's advice guides the safe and efficient remediation of the affected buildings, ensuring that rectified buildings can be fully and affordably insured.

In close consultation with the Project Remediate Global Façade Consultant, the Panel provides guidance on façade system design standards for each building, agrees product and component suitability and arranges testing of products and remediation systems as required.

A crucial element of Project Remediate is this Pattern Book. It provides best-practice guidance on remediation designs and systems and addresses common cladding replacement situations. It will act as a shared body of knowledge to assist designers and deliver consistent quality and safety standards.

The Pattern Book is an enduring publication that is intended to live on beyond Project Remediate. It will lift the standards of cladding replacement practices and reduce the impact of flammable cladding on communities across NSW.

Tanya O'Brien
Director, Office of Project Remediate

Professor Mark Hoffman
Chair, Cladding Product Safety Panel

Update Schedule

Issue	Date	
1	09/08/2022	Issue of Project Remediate: Cladding Replacement Pattern Book (1 st edition)
2	05/05/2023	Issue of Project Remediate: Cladding Replacement Pattern Book (2 nd edition)

Contents

Foreword	2
Update Schedule	3
Contents	4
Chapter 1: Introduction	7
Chapter 2: Design and Building Practitioners Act	11
Chapter 3: Project Remediate	15
Chapter 4: Cladding Product Safety Panel	19
Chapter 5: Performance and Testing Requirements	23
Chapter 6: Product Traceability	45
Chapter 7: Sustainability in Remediation	49
Chapter 8: Certifications on Completion	55
Chapter 9: Product Warranties	59
Chapter 10: Fire Cavity Barriers	61
Chapter 11: Condensation Management	73
Chapter 12: Durability	81
Chapter 13: Thermal Performance	85
Chapter 14: Wind Loading	89
Chapter 15: Triage Investigations	97
Chapter 16: Rainscreen Façades	103
Chapter 17: Use of the Pattern Book	117
Chapter 18: Case Studies	123
Definitions	127



Introduction



akm
PROJECTS
BUILDING QUALITY
DELIVERING CARE
www.akmprojects.com.au

Chapter 1:

Introduction

The importance of proper design consideration in all façade remediation projects cannot be overstated. Detailed design is essential to deliver outcomes that not only rectify problems in façades, but also consider the wholistic performance, engineering and aesthetic of the buildings.

Through Project Remediate, the NSW Government has commissioned the development of this Pattern Book. The Pattern Book has been developed by the Global Façade Consultant (GFC) for Project Remediate to serve as a resource to guide the consideration and design of remediation works for buildings being planned across NSW.

The Pattern Book is not only a critical reference document for designers working on Project Remediate buildings but also provides a reference for industry undertaking private façade remediation in all buildings.

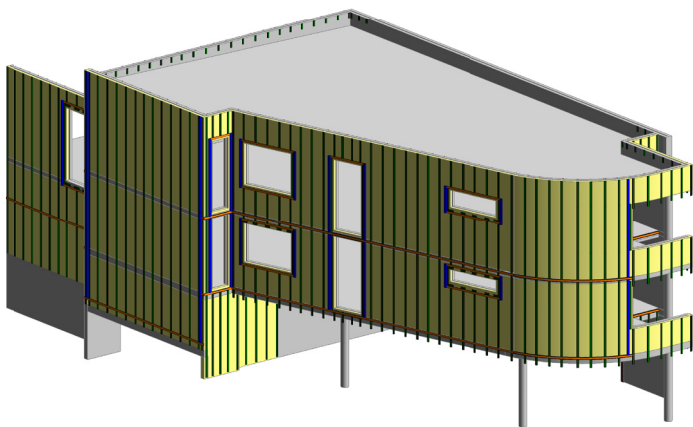

Figure 1.1: Example cladding replacement configuration (isometric)

The role of the Global Façade Consultant (GFC)

ACOR has been appointed as the GFC for Project Remediate – this role promotes quality engineering standards across all Project Remediate buildings. Following the commencement of Project Remediate, the GFC have provided guidance in the design and procurement of suitable façade remediation solutions through collaboration with the Managing Contractor, Cladding Product Safety Panel and the individual design teams engaged for each remediation project.

Following the commencement of the Project Remediate programme, the GFC have been providing essential engineering advice to guide the remediation work, providing direction in responding to Council's issued fire orders and ultimately returning insurable buildings to the market.

The GFC have interacted with the building assessment/investigation contractors, design teams and remediation contractors who have been appointed for each individual building from the panel of approved providers. Building assessment contractors and design teams have been investigating the cladding and wall assembly methods of each building and providing reports and design documentation to the GFC.

About this Pattern Book

The Project Remediate Pattern Book has been developed and is maintained by the Global Façade Consultant in consultation with the:

- Cladding Product Safety Panel
- Managing Contractor
- Program BCA consultant
- Building investigation and design teams.

This reference document will continue to be utilised by all the design teams and building contractors on Project Remediate in facilitating standard solutions and minimising redundant re-design work. The Pattern Book provides:

- Details of the preferred remediation design approaches for standard building features that are found in a cladding remediation development
- A schedule of the typical building components require validation in the form of approved certificates or similar, the schedule of materials used (e.g., screws, rivets, packers, fire barriers, cladding, etc.), and;
- A schedule of inclusions for the remediation assurance certificates (e.g., material warranties).

The Pattern Book document continues to be reviewed and kept up to date throughout the life of Project Remediate. Project Remediate will also release versions of this Pattern Book as a public reference document as amended from time to time.

The content of this document is intended to be used by Registered Design Practitioners or suitably qualified consultants, and also to serve as an educational reference for students of the building industry. This is to be considered as a guidance document only. Design Practitioners must validate all aspects of the design and not reference the Pattern Book in their design declarations or design certifications.

The details and wall typologies have been generated to suit the reclad of apartments or Class 2 buildings as defined by the NCC, but may also be used for the reclad of other types of buildings where applicable.

Building elements

The Pattern Book provides guidance on the key design considerations, including:

- Weathertightness
- Structural behaviour
- Interaction with the primary structure
- Thermal gains and losses through the façade
- Condensation
- Ventilation
- Fire behaviour of the building envelope
- Safety and serviceability
- Durability and maintenance
- Buildability and installation
- Façade inspection and remediation
- Testing.

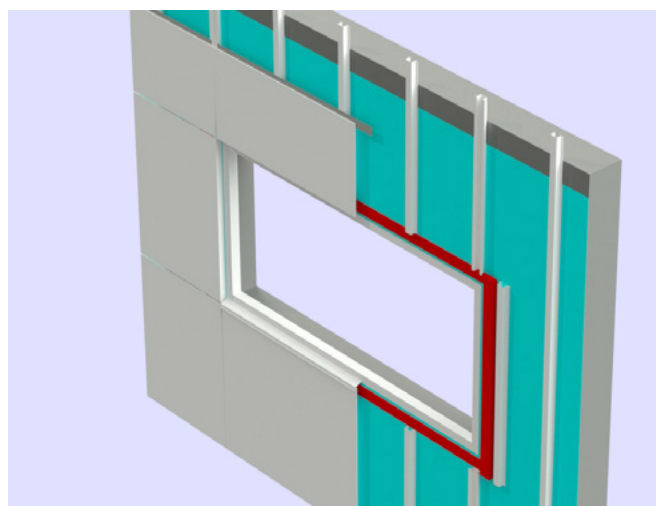

Figure 1.2: Aluminium clad façade system

The Pattern Book is a guidance document only and in no way relieves Design Practitioners from their obligations in providing a declared design specific to each individual application.



Design and Building Practitioners Act



Chapter 2:

Design and Building Practitioners Act

The framework for the design and construction of the works under Project Remediate is based upon the principles of accountability and certainty delivered through the Design and Building Practitioners Act.

On 1 July 2021, The Department of Fair Trading introduced changes to the residential building industry to restore consumer confidence and ensure that apartments being built are trustworthy.

Among the changes are two new registration schemes for Class 2-related work: one for Professional Engineers and one for Designers and Builders.

Find out more about how the changes affect Professional Engineers and Design and Building Practitioners:

[Professional Engineers](#)



What are the changes?

Changes are starting with Class 2 buildings. These are typically multi-unit, multi-storey residential buildings where people live above and below each other.

Class 2 is regarded as the highest priority right now, but the NSW Government will expand the reforms to other classes of construction in the future.

Certain designs need to be declared for compliance with the Building Code of Australia and other relevant standards before building work can commence, and declared designs must be lodged on the [NSW Planning Portal](#). Builders must then construct according to those designs.

These changes are to ensure that buildings are built to industry best practice, that the industry is more customer-focused, and that better data is captured throughout the building life cycle.

Practitioners are required to resolve design issues before construction begins – saving everyone involved time and money, and avoiding disappointment and stress for customers.

These changes form part of the [NSW Government's response to the Shergold Weir Building Confidence Report](#) that committed to strengthening compliance in the building sector.

The changes began on 1 July 2021 when the [Design and Building Practitioners Act 2020](#) and [supporting Regulation](#) commenced.

Registered Practitioners are listed publicly and can be found by searching the [Public Register for Design and Building Practitioners](#).



Recommended Reading

[Design and Building Practitioners Act 2020](#)

[Design and Building Practitioners Regulation 2021](#)

[Consultation Report – Design and Building Practitioners Regulation 2021](#)

[Public Register for Design and Building Practitioners](#)

[NSW Government’s response to the Shergold Weir Building Confidence Report](#)

[Class 2 building industry reforms | NSW Fair Trading](#)

[Building Ministers Forum Expert Assessment – Building Confidence.pdf \(industry.gov.au\)](#)

[TAFE NSW offers a short on line course “Project Remediate: Understanding the program” which is highly recommended](#)



Project Remediate

3

Chapter 3:

Project Remediate

Project Remediate is a three-year program to help remove combustible cladding from over 200 buildings known to the [Cladding Taskforce](#).

The NSW Cladding Taskforce was established to identify buildings with potentially combustible cladding and support local councils to address the use of non-compliant cladding materials.

The Taskforce audited 185,000 building records, with several thousand having been inspected.

To determine if cladding is present and poses a higher risk, Fire and Rescue NSW (FRNSW), on behalf of the NSW Cladding Taskforce, conducted an operational assessment of each building. Buildings considered a higher risk were referred to consent authorities (local councils or Department of Planning, Industry and Environment) for further investigation. A significant number of these have already been cleared.

Buildings are considered cleared if:

- They do not have cladding that FRNSW considers increases safety risks
- The cladding has been investigated and cleared by a consent authority
- Unsafe cladding has been fully remediated.

Eligible building owners will be helped through:

- Interest-free loans over a 10-year period with repayments to commence upon completion of the work
- Assurance and program management services to provide technical and practical support to owners corporations and strata managing agents.

Project Remediate is a voluntary program.

Hansen Yuncken has been appointed by the NSW Government as Managing Contractor to coordinate all activities necessary to deliver a safe and durable solution for each building.

They will guide owners corporations through the process from start to finish, keeping them informed of work or decisions affecting the building and matters relating to design, scheduling, safety and building access.

They will procure the services of qualified and reputable industry experts to deliver the work to the highest standards of safety and quality.

Detailed condition inspections (“triage investigations”) will be undertaken for each building to identify the scope of works and provided information to the design teams to enable fully documented designs to be developed.

Other measures that support the remediation services under this program include:

- Verification by a qualified professional to confirm that the work and documentation is compliant with standards under the program
- Regulatory powers held by the Office of the Building Commissioner to obtain building documentation, investigate building work and situations and issue orders for rectification.

Training for the Industry

Project Remediate seeks to raise the standards of the building industry through training and education and has partnered with TAFE NSW to deliver short online courses.

Remediate Delivery Structure

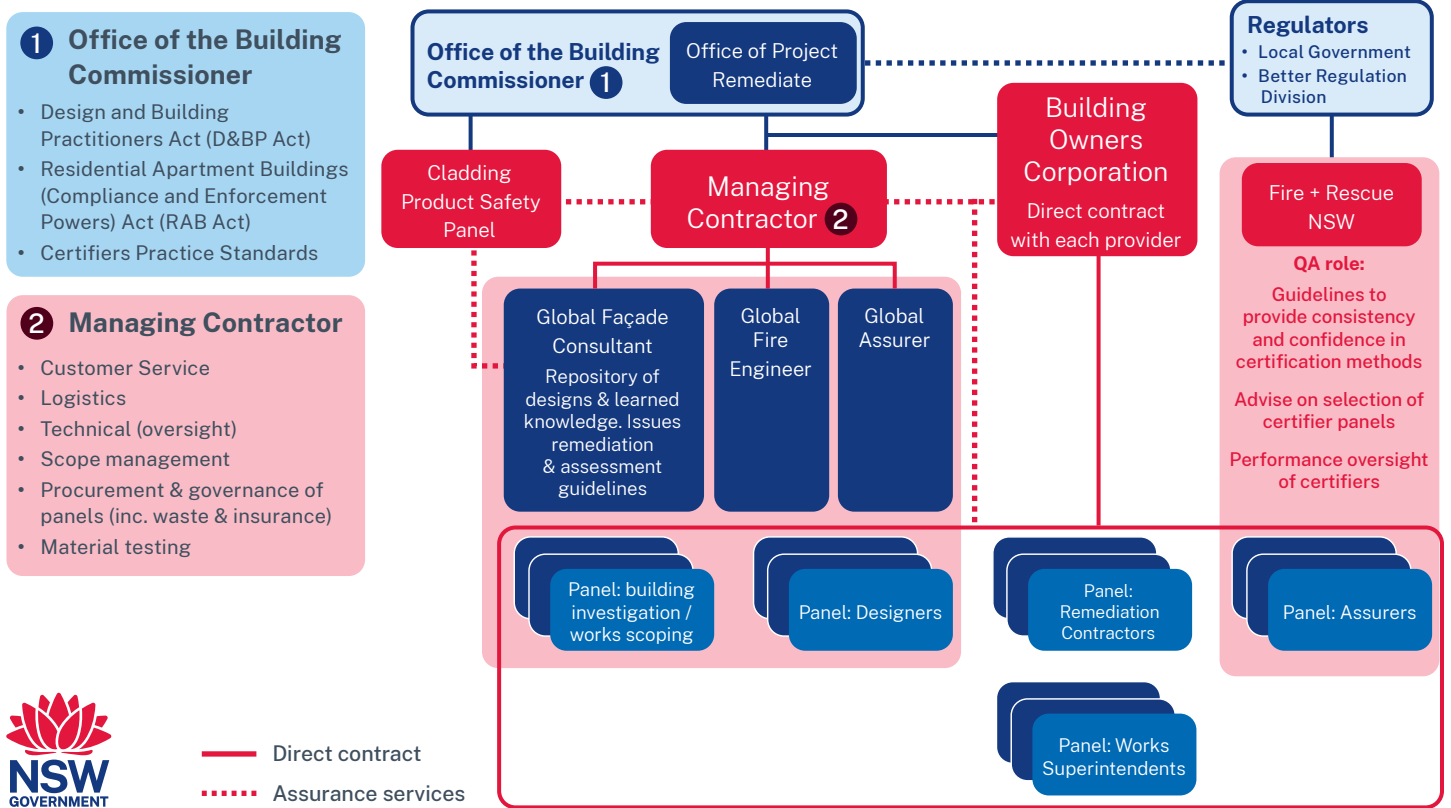

Recommended Reading

- [Cladding Product Safety Panel | NSW Government](#)
- [NSW Cladding Taskforce | NSW Government](#)
- [Apartment owners guide to Project Remediate \(nsw.gov.au\)](#)
- [Ethics in Construction](#)
- [Waterproofing remediation: How to ensure a successful project](#)



Recommended Viewing

NSW Government Media

- [Play video](#) Project Remediate – YouTube
- [Play video](#) Project Remediate – A message from the Minister for Better Regulation and Innovation – YouTube



Cladding Product Safety Panel

4

Chapter 4:

Cladding Product Safety Panel

The Cladding Product Safety Panel is a key participant in the development of the technical aspects of Project Remediate and has formed the foundations for the Pattern Book.

About the panel

The Cladding Product Safety Panel (CPSP) has expertise in fire safety engineering, product testing, building surveying and certification, and construction and building insurance. Panel members were appointed by the Minister for Better Regulation and Innovation on 29 July 2020.

The CPSP provides expert advice to the [NSW Cladding Taskforce](#) and the Cladding Support Unit on the suitability of cladding replacement products and external wall assembly methods.

Advice from the CPSP informs the cladding rectification work carried out under [Project Remediate](#); the NSW Government's program providing no-interest loans and an assurance service for the remediation of combustible cladding on high-risk residential buildings.

The CPSP is also designed to ensure that rectified buildings can be fully and affordably insured by enabling the insurance industry to better quantify cladding risks and risk control measures.

The CPSP's advice is made available to assist councils, consent authorities and building owners to make consistent, sustainable and cost-effective decisions in relation to cladding rectification work.

CPSP Reports

The CPSP provide periodical reports to the NSW Government. These reports are made available for the benefit of building owners and the cladding remediation industry.

CPSP Report 1 (19 April 2021)

The CPSP has provided its first report to Government on cladding products.

The report includes advice and recommendations on how potentially flammable cladding should be assessed and replaced for buildings participating in Project Remediate.

The recommendations of this report do not apply to, and are not required to be met by, other classes of buildings or residential apartment buildings that are not being remediated as part of the Government's Project Remediate program.

It also provides an initial list of recommended replacement products for buildings participating in the program.

Importantly, the report includes recommendations on wall system design and installation requirements necessary to support safe cladding remediation, including:

- Requiring mechanical fixing of cladding panels (not glue or tape)
- The installation of cavity barriers in appropriate locations to prevent the spread of smoke or flame
- Cladding replacement systems that are fully designed for each building by appropriate professionals, taking into account structural and wind loading considerations, weatherproofing, condensation and other matters.

While the report recommends replacement product categories for buildings participating in the program, no individual material or brand has been endorsed by the CPSP. Individual products will need to meet the CPSP's requirements, including testing, before they are used.

CPSP Report 2 (28 April 2022)

The CPSP has provided its second report to Government on cladding products. The report provides an update on the activities which ensued following the issue of Report 1 and included the following:

- Engagement with suppliers to gather detailed information on materials proposed for use in Project Remediate;
- Publication of a consolidated list of materials that have been proposed and are currently under CPSP consideration;
- Consultation with suppliers and the development of a 'reference' material test to inform the CPSP's assessment of bonded laminated materials proposed for use in Project Remediate;
- Findings of 'reference' material testing, and recommendations related to additional cladding materials endorsed for use in Project Remediate.

List of materials submitted to the CPSP

Cladding materials which are proposed for use in the program are subject to a comprehensive review process. Manufacturers must demonstrate compliance with the requirements of the program through the provision of documentary evidence. Each cladding material submission is reviewed by the Managing Contractor and advice provided by the GFC before being put forward to the CPSP for approval. The Managing Contractor liaises with the industry in obtaining all necessary data which sufficiently demonstrates compliance. This data is collated and forms part of a consolidated list of cladding materials which may be relied upon by Design Practitioners in assessing compatibility with the program requirements. For those wishing to supply cladding materials or systems, they may do so through the [online application](#) process where further information can be obtained outlining the requirements of such.

It is important to note that this list **does not** represent cladding replacement products/systems that have been endorsed. This information is published to provide transparency about the cladding products and systems submitted for consideration. The list includes certain information about each material based on the submission, or information obtained from other sources such as supplier websites. The accuracy of this information has not necessarily been verified.

The [online application to supply cladding materials or systems](#) is still open. As a consequence, this consolidated list of submitted materials will be updated periodically.

Panel membership

The CPSP is an advisory committee for the Commissioner for Fair Trading, Building Commissioner and the Fire Safety & External Wall Cladding Taskforce pursuant to section 9B of the Fair Trading Act 1987. The eight-member panel is chaired by Professor Mark Hoffman, who led the investigation into building failures at Mascot and Opal towers.

The following have been appointed until 28 July 2023:

- Chair – Professor Mark Hoffman
- Member – Mr Stephen Durnford, NSW Department of Customer Service
- Member and Deputy Chair – Dr Marianne Foley, building and construction expert
- Member – Mr Allan Harriman OAM, fire safety engineering expert
- Member – Mr Robert Marinelli, building surveying and building work certification expert
- Member – Mr Stephan Netting, Fire and Rescue NSW
- Member – Professor Bijan Samali, fire safety engineering expert
- Member – Mr Michael Hunneyball, Insurance Council of Australia.

The CPSP meets to discuss matters and formulate advice. The Department of Customer Service provides secretariat and other services to support the Panel's work.

The panel's role

The CPSP provides expert advice but does not have regulatory or decision-making powers. Consent authorities (local councils) remain the relevant regulatory authorities responsible for assessing the safety and compliance of buildings, issuing and enforcing rectification orders and determining the suitability of rectification proposals.

The CPSP provides advice to the Cladding Taskforce and the Cladding Support Unit, which shares relevant advice with local councils in line with the existing support arrangements. Advice that is of wider interest or application is published and made available for building owners and industry practitioners to access when they are making decisions about particular products or solutions that might be used in the rectification of buildings.

What the panel will consider

The CPSP's immediate focus is on developing sound assessment processes and assessing cladding products and systems in order to provide a list of 'preferred' products for use in Project Remediate. It is anticipated that this list will be developed and added to over time as the CPSP continues its work. Matters can be submitted for consideration by completing the [application form](#).



Recommended Reading

[NSW Cladding Taskforce | NSW Government](#)

[Cladding Product Safety Panel Report 1](#)

[Cladding Product Safety Panel Report 2](#)

Performance and Testing Requirements



5

Chapter 5:

Performance and Testing Requirements

The designs for all elements of the recladding including sub framing, fasteners and sealants are to be in accordance with NCC 2019 (Amendment 1) in addition to any special conditions which have been recommended by the Cladding Product Safety Panel. This chapter highlights some relevant issues, however, the overall provisions of the NCC must be considered holistically.

Note: NCC 2022 becomes in force from 1 May 2023

Deemed to Satisfy Requirements of NCC 2019 (+A1)

Fire resistance

Clause C1.9 (a) (i) of NCC 2019 specifies that for External walls of Type A construction, all components of the façade must be non-combustible including covering, framing and insulation. Refer to ABCB Advisory Note 2020.2.3 Fire Performance of External Walls and Cladding for further information.

Under Schedule 3 of the NCC:

Non-combustible means:

- a. applied to a material – not deemed combustible as determined by AS 1530.1 – Combustibility Tests for Materials; and
- b. applied to construction or part of a building – constructed wholly of materials that are not deemed combustible.

Exemption is given under clause C1.9 (d) to the following elements:

- A. Gaskets.
- B. Caulking.
- C. Sealants.
- D. Termite management systems.
- E. Glass, including laminated glass.
- F. Thermal breaks associated with glazing systems.
- G. Damp-proof courses.

It is anticipated that this list will be augmented in future editions of the NCC.

Clause C1.9 (e) also provides a list of materials which may be used wherever a non-combustible material is required:

- A. Plasterboard.
- B. Perforated gypsum lath with a normal paper finish.
- C. Fibrous-plaster sheet.
- D. Fibre-reinforced cement sheeting.
- E. Pre-finished metal sheeting having a combustible surface finish not exceeding 1 mm thickness and where the Spread-of-Flame Index of the product is not greater than 0 (as tested to AS 1530.3).
- F. Sarking-type materials that do not exceed 1 mm in thickness and have a Flammability Index not greater than 5 (As tested to AS 1530.2).

In addition to the requirements for materials and assemblies to be non-combustible, Clause C1.10 specifies performance requirements for certain elements within Class 2 to 9 buildings.

Sarking type material of any thickness is to have a Flammability Index not greater than 5.

Other materials such as insulation to have a Spread of Flame Index not greater than 9 and a Smoke Developed Index not greater than 8 (if the Spread of Flame Index is more than 5).

Note that Clause C1.14 (l) allows paint finishes to be applied to external walls that are not combustible.

Evidence of Suitability

The Clause A5.2 of the NCC 2019 specifies the form of evidence required to support the use of materials as follows:

- a. A current CodeMark Australia or CodeMark Certificate of Conformity.
- b. A current Certificate of Accreditation.
- c. A current certificate, other than a certificate described in (a) and (b), issued by a certification body stating that the properties and performance of a material, product, form of construction or design fulfil specific requirements of the BCA.
- d. A report issued by an Accredited Testing Laboratory that:
 - i. demonstrates that a material, product or form of construction fulfils specific requirements of the BCA; and
 - ii. sets out the tests the material, product or form of construction has been subjected to and the results of those tests and any other relevant information that has been relied upon to demonstrate it fulfils specific requirements of the BCA.
- e. A certificate or report from a professional engineer or other appropriately qualified person that:
 - i. certifies that a material, product, form of construction or design fulfils specific requirements of the BCA; and
 - ii. sets out the basis on which it is given and the extent to which relevant standards, specifications, rules, codes of practice or other publications have been relied upon to demonstrate it fulfils specific requirements of the BCA.
- f. Another form of documentary evidence, such as but not limited to a Product Technical Statement, that:
 - i. demonstrates that a material, product, form of construction or design fulfils specific requirements of the BCA; and
 - ii. sets out the basis on which it is given and the extent to which relevant standards, specifications, rules, codes of practice or other publications have been relied upon to demonstrate it fulfils specific requirements of the BCA.

Structural Adequacy

The NCC references design standards for elements manufactured from materials such as steel and aluminium. These standards will cover many of the commonly used components such as secondary framing supporting cladding and fasteners. Elements designed to these standards are deemed to satisfy the requirements of the NCC. Some design standards include methods to demonstrate adequacy through testing as an alternative to calculation.

Where a material is to be used which is not covered by a Standard referenced in the NCC then a method of complying with the Performance Requirements (via. a *Performance Solution*) will be required which may involve the use of international standards or prototype testing. Where international standards are used, consideration must be made as to the applicability of these standards when used in Australia and in conjunction with Australian standards. For example the use of load factors and partial safety factors. AS1170.0 provides a general methodology to undertake prototype testing.

Validation of the adequacy of an installation may be undertaken through on-site proof testing. This is relevant for fasteners fixed to existing substrates.

For Class 2 buildings a registered Professional Engineer will be required to produce a Declared Design and certify the structural adequacy of the installation which will encompass calculations and any testing.

Durability

The durability of materials is generally covered by Australian Standards. Protection of metal products is to be in accordance with AS 2312 series. Protection systems are based on Life to First Maintenance and is to be selected by the specifier.

Evidence that the protection systems are adequate relate to the workmanship of the applied coatings and thicknesses and will generally be demonstrated through Quality Assurance processes and product warranties.

Weatherproofing and Moisture Management

There is no Deemed-to-Satisfy pathway of meeting Performance Requirement FP1.4 under the NCC (2019). In this regard, the only method of complying with this Performance Requirement under NCC 2019 is through the preparation of a Performance Solution.

An appropriate assessment method (or a combination thereof) under NCC Clause A2.2 must be utilised to demonstrate compliance with the Performance Requirements. This could include the use of Verification Method FV1.1, reliance on expert judgement, references to scientific literature, and / or any other appropriate method as deemed acceptable by the project stakeholders.

Testing and Validation for Project Remediate

Project Remediate is to deliver cladding replacement solutions which can be proven to be compliant to the requirements of the NCC and follow current best practice.

Products used in this program are to be approved by the Cladding Product Safety Committee.

Fire safety

The CPSP is continually reviewing submissions made. At the time of writing, 6 materials have been approved for re-clad use:

- Solid Aluminium
- Solid Metal Sheets
- Fibre Cement
- Non-combustible Cement Render
- Engineered Ceramic Cladding Systems (ECCS)
- Bonded Laminated Materials (BLM).*

* Bonded Laminated Materials (BLM) are subject to Project Remediate reference testing.

Other materials and components must demonstrate compliance with the requirements of the NCC through the provision of test certificates. Testing will predominantly be based on AS 1530.1 to 4.

The CPSP endorsed the use of bonded laminates provided these can be demonstrated to comply with the CPSP reference material testing, as set out within Report 2: Appendix 2. In preparing this Report, the CPSP developed a framework of performance tests to be applied to these products.

To ensure fire safety, any chosen product is to be mechanically fastened. Reliance on adhesives and double-sided tape to secure the cladding to the building structure is not permitted for Project Remediate.

The CPSP has informed the Cladding Taskforce of the requirement to install cavity barriers within the cavity directly behind the external cladding (CPSP Report 1). The provision of such components reflect best practice and are a requirement for all buildings involved in Project Remediate.

Proof of compliance with the Standards set out in the following sections will be required for any product to be used in Project Remediate.

Bonded Laminated Materials (BLM) – Additional Testing

CPSP Report 2 specifies additional testing requirements beyond that stipulated within AS/NZS 1530.3. These additional testing requirements are necessary in demonstrating compliance of Bonded Laminated Materials (BLM) with the 'Deemed to Satisfy' provisions of the Building Code of Australia (BCA).

Report 2 states that in addition to the testing requirements set out within AS/NZS 1530.3 for determining Spread of Flame (SOF) and Smoke Developed (SD) indices, as well as the associated limits for compliance as specified within Schedule 6

of the National Construction Code (NCC), the following additional measures shall be satisfied:

Joints

To test the performance of BLM with joints, a specimen including a combined horizontal and vertical 12 mm silicone-filled joint with backing rod is proposed.

Perforations

To test the performance of BLM with perforations, specimens shall be prepared with both a 20 mm x 20 mm penetration (e.g., electrical cable) and a 200 mm x 200 mm penetration (e.g., cut-out for bathroom exhaust) with an edge of the perforation located at the centre of the specimen. The specimen shall be positioned within the testing apparatus such that the pilot flame aligns with an exposed edge of the perforation. Figure 5.2 illustrates this for the 200 mm x 200 mm scenario.

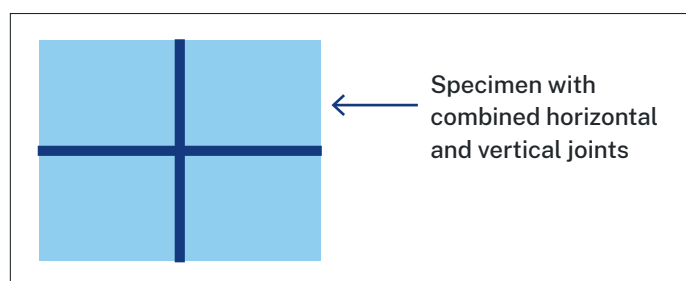

Figure 5.1: Illustration of joint to be tested

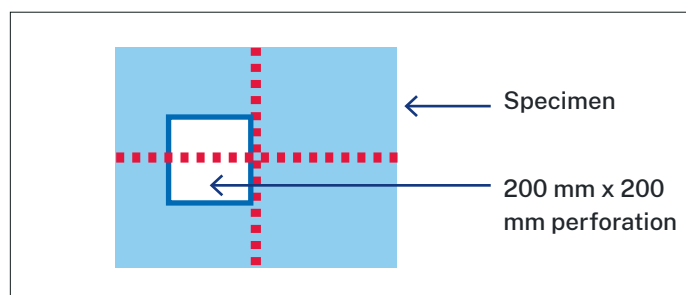

Figure 5.2: Illustration of 200 x 200 mm perforation. The intersection of the dashed line indicates the position of the pilot flame

The following specimens shall comprise a sample for the reference material testing:

- 9 specimens of BLM with no perforations and no joints
- 9 specimens of BLM with electrical cable-sized perforation (20 mm x 20 mm)
- 9 specimens of BLM with perforation such as bathroom exhaust (200 mm x 200 mm)
- 9 specimens of BLM prepared with intersecting horizontal and vertical joints.

In accordance with Clause 4.4.9 of AS/NZS 1530.3, where both front and rear faces of BLM have different specifications (e.g., different thicknesses, different coatings), separate tests shall be conducted with both front and rear faces of the specimen exposed to the heat source/pilot flame. In this case, twice the number

of specimens shall be required. Additionally, the number of test samples increases in instances where there are differences between the materials forming the front and rear faces of the composite panel.

The table below summarises the indicative samples for the proposed testing.

Indicative samples for the proposed testing

Dimensions of each specimen	600 ±5 mm X 450 ±5 mm
No. of specimens required (no perforation, no joint)	9
No. of specimens required with electrical cable-sized perforation (Perforation is 20 mm x 20 mm)	9
No. of specimens required with exhaust-sized perforation (Perforation is 200 mm x 200 mm)	9
No. of specimens required with both horizontal and vertical joints (12 mm silicone-filled joints with backing rod)	9

Notes:

1. The sample requirements are indicative only. This may vary depending on the requirements of the test facility and number of dissimilar faces of the BLM.
2. Please refer to AS/NZS 1530.3 for appropriate mounting procedure for the specimens.

Material/component	AS 1530.1	AS 1530.2	AS 1530.3	Other Standards
Aluminium Metal Sheeting (Cladding) with coating less than 1mm thick	N/A		Spread of Flame Index not greater than 0	
Compressed Fibre Cement Sheet*	N/A			
Metal Cladding (with no finishes)	N/A			
Engineered ceramic cladding systems	Not combustible			
Steel top hats	N/A			
Aluminium top hats	N/A			
Sarking < 1mm thick	N/A	Flammability Index not greater than 5		
Sarking >1mm	Not combustible	Flammability Index not greater than 5		
Insulation	Not combustible		Spread of Flame index not greater than 9 And Smoke Developed index not greater than 8 if Spread of Flame Index is more than 5	
Closed-state Cavity Barriers	AS 1530.1 [#]			AS 1530.4
Open-state Cavity Barriers	^			TGD 19

* This is "Fibre reinforced cement sheeting" as stated in Clause C1.9 (e) (iv) of NCC 2019.

^ It should be noted that open-state cavity barriers are deemed incompatible with the testing methodology of AS 1530.1. This is due to the products relying upon the use of intumescently coated material which may respond to such testing in a manner which wholly prevents the accurate recording of performance and assessment of the corresponding temperature-curve gradient. Designers should be aware that a Performance Solution may be necessary for such materials/components.

It should be noted that closed-state cavity barrier *products* often incorporate a film surround (coating) primarily functioning in protecting the core material against moisture ingress. Where such products are adopted, the *product* may be unable to achieve compliance against the requirements of AS 1530.1 given this Standard applies to individual materials/components. Designers should be aware that a Performance Solution may be necessary for such materials/components.



Figure 5.3: Fire test to AS 1530.1 (Source: ISpecify)

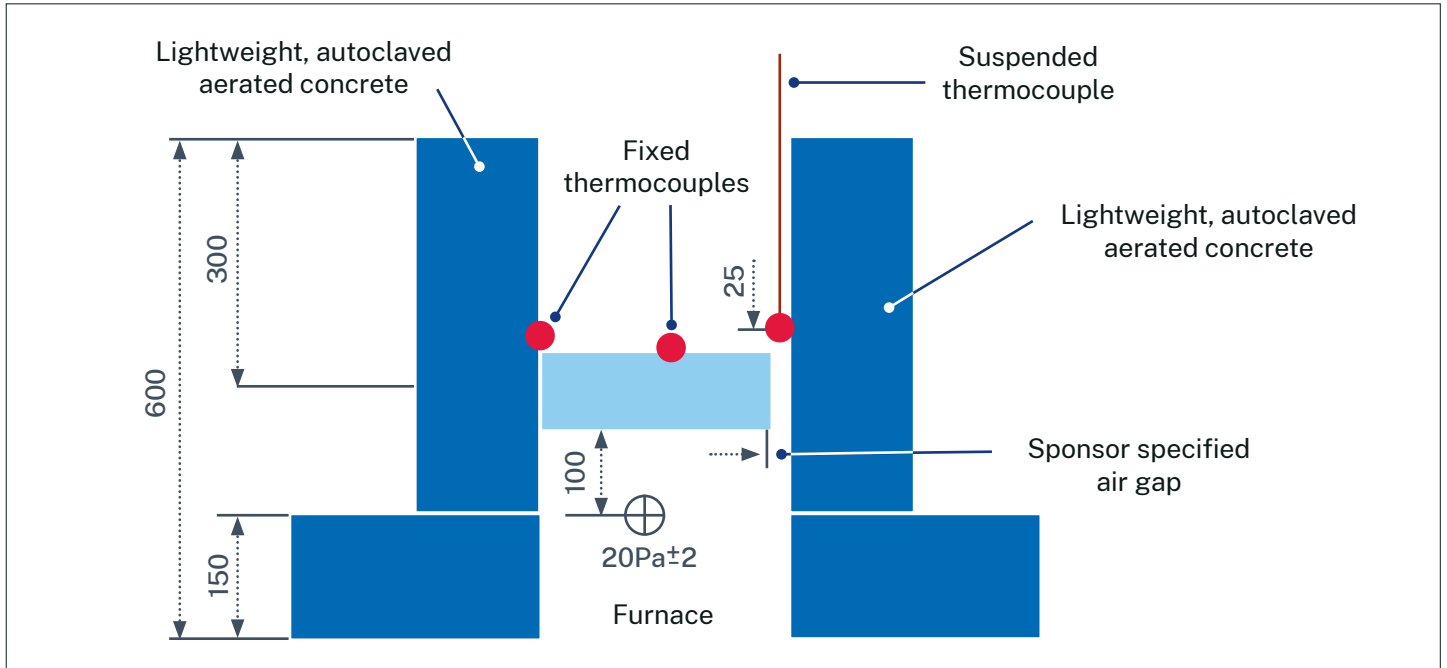

Figure 5.4: Fire test to TGD 19

Structural Adequacy

Structural adequacy will be ensured through the application of material design standards in accordance with the structural design procedure defined within AS/NZS 1170.0. This Standard defines the Ultimate and Serviceability Limit States which are used as a means of demonstrating compliance with the requirements of Part B1 of the Building Code of Australia together with the relevant material Standard where available. It also references the additional Standards which inform the relevant structural design actions to be adopted in design, namely AS 1170.1 to AS 1170.3 as well as AS/NZS AS 1170.4.

Where no material Standards are available then testing in accordance with AS 1170.0 should be undertaken for both serviceability and ultimate limit states. The use of alternate test methods may be permitted subject to a review by the GFC and subsequent approval of the CPSP of the validity and applicability of the procedure.

There are a number of facilities in NSW where structural prototype testing can be readily undertaken. Where any doubt exists with the performance of a product then a test undertaken locally to AS 1170.0 is recommended.

Material/component	Method of compliance	Alternate Method of Compliance
Solid Aluminium	Declared Design to AS 1664	Prototype testing in accordance with AS 1664
Solid Metal Sheets	Declared Design to AS/NZS 4600	Recognised international standard to Principal Designers endorsement
Compressed Fibre Cement	Prototype testing to AS 1170.0	Prototype testing to AS 4600 or AS 1170.0
Engineered Ceramic Cladding Systems (ECCS)	Testing to AS 1170.0	Recognised international standard to Principal Designers endorsement
Bonded Laminated Materials (BLM)	Prototype testing to AS 1170.0	Recognised international standard to Principal Designers endorsement
Aluminium Subframing	Declared Design to AS 1664	Prototype testing to AS/NZS 1664.1
Cold-formed Steel Subframing	Declared Design to AS/NZS 4600	Prototype testing to AS/NZS 4600

Prototype testing is preferred to be undertaken by a NATA approved laboratory, however where this is not possible a peer review by an accredited organisation is acceptable.

Durability

For metal products, corrosion protection should be provided that the life to first maintenance is greater than 15 years (i.e. “Very Long Term”). Coating composition and thickness must be demonstrated through Quality Inspection records.

Note that care needs to be taken with products formed from galvanized sheet as cut ends and perimeters of holes are exposed to corrosion. These edges must be primed with a suitable applied finish.

The designers must also assess the remaining life of the coatings which protect any existing subframing which may remain.



Figure 5.5: Care must be taken with products formed from galvanized sheet to prevent corrosion

Base materials

Evidence will be required to demonstrate that the materials supplied are as per the specifications. In practice, this will be achieved through the provision of material certificates and sampling of supplied materials.

Permeability of Sarking

Sarking is to be Class 3 or 4 in accordance with AS 4200.1.

Note that pliable membranes can only be used at low-to-medium wind pressures. For greater values, rigid air barriers should be considered.



Figure 5.6: Masonry pull-out test

Weatherproofing

The triage report will identify the weatherproofing system for each wall. If there is no clear weatherproofing system then a sarking of appropriate permeability and proof of performance through testing should be installed. Joints and interfaces should be detailed using recognised methods in accordance with the manufacturer’s guidance. The waterproofing is to be demonstrated through hose testing of the interfaces.

Installation – on-site testing

To ensure workmanship, validate substrate capacity and identify situations in the existing wall system, on-site testing is recommended to provide assurance of the quality of the final installation.



Figure 5.7: Window hose testing

Pull-out tests for masonry anchors

Pull-out tests for fixings to existing masonry, concrete and AAC are to be undertaken in accordance with the principles established in AS 1170.0. This will confirm the products have been installed in accordance with the manufacturer’s specification and also that the substrate has the inherent capacity to provide the required resistance.

Hose testing

Host testing to AAMA 501.2 Quality Assurance and Diagnostic Water Leakage Field Check of Installed Storefronts, Curtain Walls, and Sloped Glazing Systems can be readily undertaken and will be of value to confirm that interfaces between new and existing components have been adequately sealed.

National Construction Code (NCC) 2022 Implementation

The **National Construction Code (NCC) 2022** was released by the Australian Building Codes Board (ABCB) on 1 October 2022 and is scheduled for adoption within New South Wales (NSW) from 1 May 2023. Up until this date, the provisions stipulated within the existing National Construction Code (NCC) 2019 Amendment 1 (+A1) remain in-force. From the date of adoption, buildings which are subjected to a new Fire Order shall be assessed against the requirements of NCC 2022. Buildings which have already been subjected to a Fire Order prior to the date of adoption shall continue to be assessed under the NCC relevant at the time of assessment.

NCC 2022 Volume One contains amendments to the fire safety of external walls which affects the requirements attributed to the external walls (such as fire safety, weatherproofing, etc.). This clarifies interpretation of concessions from non-combustibility requirements as well as a new provision preventing the fixing of certain bonded laminated cladding panels through use of structural adhesives only as is described to follow.

Deemed-To-Satisfy (DTS) provisions have been updated within NCC 2022. The requirements pertaining to *Non-combustible building elements* have been updated to reflect an increased volume of listed building elements which are listed as exempt from the non-combustibility requirements (e.g. concessions) set out in the preceding Clauses. A noticeable update relates to Clause C2D10 (4) (NCC 2022) which replaces Clause C1.9(d) (NCC 2019). This Clause has expanded upon the “thermal breaks” component. It also now includes various additional building components, as are listed within the below summary table:

NCC 2019 (+A1)	NCC 2022
Clause C1.9 (d)	Clause C2D10 (4)
The requirements of (a) and (b) do not apply to the following:	The requirements of (1) and (2) do not apply to the following:
i. Gaskets.	a. Gaskets.
ii. Caulking.	b. Caulking.
iii. Sealants.	c. Sealants.
iv. Termite management systems.	d. Termite management systems.
v. Glass, including laminated glass.	e. Glass, including laminated glass, and associated adhesives, including tapes.
vi. Thermal breaks associated with glazing systems.	f. Thermal breaks associated with–
vii. Damp-proof courses.	i. glazing systems; or
	ii. external wall systems, where the thermal breaks–
	A. are no larger than necessary to achieve thermal objectives; and
	B. do not extend beyond one storey; and
	C. do not extend beyond one fire compartment.
	g. Damp-proof courses.
	h. Compressible fillers and backing materials, including those associated with articulation joints, closing gaps not wider than 50mm.
	i. Isolated–
	i. construction packers and shims; or
	ii. blocking for fixing fixtures; or
	iii. fixings, including fixing accessories; or
	iv. acoustic mounts.
	j. Waterproofing materials applied to the external face, used below ground level and up to 250 mm above ground level.
	k. Joint trims and joint reinforcing tape and mesh of a width not greater than 50mm.
	l. Weather sealing materials, applied to gaps not wider than 50 mm, used within and between concrete elements.
	m. Wall ties and other masonry components complying with AS 2699 Part 1 and Part 3 as appropriate, and associated with masonry wall construction.
	n. Reinforcing bars and associated minor elements that are wholly or predominately encased in concrete or grout.
	o. A paint, lacquer or a similar finish or coating.
	p. Adhesives, including tapes, associated with stiffeners for cladding systems.
	q. Fire-protective materials and components required for the protection of penetrations.

Clause C2D10 (5) is introduced within the NCC 2022 as an addition to those stipulated within NCC 2019. The Clause provides a list of non-combustible materials as defined by those which are “entirely composed of itself”. This lists those materials which adhere to the non-combustible Deemed-To-Satisfy (DTS) requirements on the provision that these are individual materials rather than a composition of multiple or forming part of an overall system. This additional clause lists the building materials below:

NCC 2019 (+A1)	NCC 2022
N/A	Clause C2D10 (5)
No equivalent Clause	<p>The following materials, when entirely composed of itself, are non-combustible and may be used wherever a non-combustible material is required:</p> <ol style="list-style-type: none"> a. Concrete. b. Steel, including metallic coated steel. c. Masonry, including mortar. d. Aluminium, including aluminium alloy. e. Autoclaved aerated concrete, including mortar. f. Iron. g. Terracotta. h. Porcelain. i. Ceramic. j. Natural stone. k. Copper. l. Zinc. m. Lead. n. Bronze. o. Brass

Clause C2D10 (6) (NCC 2022) expands upon Clause C1.9 (e) (NCC 2019) to include an additional component referring to the fixing method used for bonded laminated materials by now referring to a separate Clause, namely C2D15 (NCC 2022).

NCC 2019 (+A1)	NCC 2022
Clause C1.9 (e)	Clause C2D10 (6)
<p>The following materials may be used wherever a non-combustible material is required:</p> <ol style="list-style-type: none"> i. Plasterboard. ii. Perforated gypsum lath with a normal paper finish. iii. Fibrous-plaster sheet. iv. Fibre-reinforced cement sheeting. v. Pre-finished metal sheeting having a combustible surface finish not exceeding 1 mm thickness and where the Spread-of-Flame Index of the product is not greater than 0. vi. Sarking-type materials that do not exceed 1 mm in thickness and have a Flammability Index not greater than 5. vii. Bonded laminated materials where– <ol style="list-style-type: none"> A. each lamina, including any core, is non-combustible; and B. each adhesive layer does not exceed 1 mm in thickness and the total thickness of the adhesive layers does not exceed 2 mm; and C. the Spread-of-Flame Index and the Smoke-Developed Index of the bonded laminated material as a whole do not exceed 0 and 3 respectively 	<p>The following materials may be used wherever a non-combustible material is required:</p> <ol style="list-style-type: none"> a. Plasterboard. b. Perforated gypsum lath with a normal paper finish. c. Fibrous-plaster sheet. d. Fibre-reinforced cement sheeting. e. Pre-finished metal sheeting having a combustible surface finish not exceeding 1 mm thickness and where the Spread-of-Flame Index of the product is not greater than 0. f. Sarking-type materials that do not exceed 1 mm in thickness and have a Flammability Index not greater than 5. g. Bonded laminated materials where– <ol style="list-style-type: none"> i. each lamina, including any core, is non-combustible; and ii. each adhesive layer does not exceed 1 mm in thickness and the total thickness of the adhesive layers does not exceed 2 mm; and iii. the Spread-of-Flame Index and the Smoke-Developed Index of the bonded laminated material as a whole do not exceed 0 and 3 respectively; and iv. when located externally, are fixed in accordance with C2D15.

Clause C2D15 (NCC 2022) Fixing of bonded laminated cladding panels represents a new addition within the National Construction Code. This Clause specifies that such cladding materials must be mechanically connected to the associated support structure.

NCC 2019 (+A1)	NCC 2022
N/A	Clause C2D15
No equivalent Clause	<ol style="list-style-type: none"> 1. In a building required to be of Type A or B construction, externally located bonded laminated cladding panels must have all layers of cladding mechanically supported or restrained to the supporting frame. 2. An externally located bonded laminated cladding panel need not comply with (1) if it is one of the following: <ol style="list-style-type: none"> a. A laminated glass system. b. Layered plasterboard product. c. Perforated gypsum lath with a normal paper finish. d. Fibrous-plaster sheet. e. Fibre-reinforced cement sheeting. f. A component of a garage door.

The mechanical fastener requirement reflects what is current practice across many suppliers and installers and will be directly applicable within the context of Project Remediate given bonded laminated products have been endorsed for use.

A further update of note within NCC 2022 Volume One is the introduction of Clause F3D5: Wall cladding. This new Clause specifies that a “metal wall cladding” element shall comply with the Australian Standard *AS 1562.1 Design and installation of metal roof and wall cladding, Part 1: Metal*.

This represents an extension of applicability of AS 1562.1 and is of particular interest given it had previously been specified as applicable to metal roof sheeting only. This Design Standard sets requirements directly related to the aluminium alloys used as well as the base metal thickness. AS 1562.1 specifies that the aluminium alloys to be used shall be either grades 5251 or 5052. It also limits the maximum temper associated with either of these aluminium alloys by specifying that these shall not exceed temper grade H38. In addition, the base metal thickness is similarly constrained when adhering to this Design Standard, and is required to be no less than 0.7mm in thickness.

The inclusion of this Clause is significant in the context of Bonded Laminated Materials in particular. These composite wall cladding systems are widely used within the industry and the standard alloys as well as base material thickness generally do not conform with the parameters listed above. It should be noted that the introduction of Deemed-to-Satisfy Clause F3D5 does not function in prohibiting the use of Bonded Laminated Materials under NCC 2022, when considering the potential to allow for the use of such products under a Performance Solution via compliance with the Performance Requirements of the NCC. This Clause instead creates a new DTS pathway for those products which achieve the various criteria contained within the referenced Australian Standard. For products which do not achieve this criteria, the adoption of a Performance Solution then becomes necessary where proposed for use in projects certified under NCC 2022. Where compliance with the Performance Requirements of the NCC is proposed to be achieved via a Performance Solution, the Performance Solution must be site and building specific and meet the criteria set out in Clauses A2G2 and A2G4 as relevant.

NCC 2019 (+A1)	NCC 2022
N/A	Clause F3D5 (1) (c)
No equivalent Clause	<ol style="list-style-type: none"> 1. External wall cladding must comply with one or a combination of the following: <ol style="list-style-type: none"> a. Masonry, including masonry veneer, unreinforced and reinforced masonry: AS 3700. b. Autoclaved aerated concrete: AS 5146.3. c. Metal wall cladding: AS 1562.1. 2. The following buildings need not comply with (1): <ol style="list-style-type: none"> a. A Class 7 or 8 building where in the particular case there is no necessity for compliance. b. A garage, tool shed, sanitary compartment, or the like, forming part of a building used for other purposes, except where the construction of the garage, tool shed, sanitary compartment or the like contributes to the weatherproofing of another part of the building that is required to be weatherproofed. c. An open spectator stand or open deck carpark

It is recommended that readers refer to the ABCB website to review the individual Clauses and familiarize themselves with the new NCC format as well as the additional requirements and updated Clauses.

The Clauses described in the preceding section represent notable updates specific to the Program in the context of this Chapter. It is recommended that readers refer to the ABCB website to review the individual Clauses and familiarize themselves with the new NCC format as well as the additional requirements and updated Clauses.

Technical Paper: 1. Fire Testing

1.1 Overview

The following Technical Paper discusses the overarching fire testing Standards and guidance methods used in determining the fire performance characteristics of various construction materials.

1.2 Introduction

It is critical that there is a comprehensive undertaking of fire testing of the constituent components which form any proposed façade system. Such testing is required to verify the systems performance under fire loading and ensure that this is within the acceptance criteria specified within the NCC.

AS 1530-Methods for fire tests on building materials, components and structures is a suite of testing standards comprising 4 components which each set out the methods to determine specific fire performance parameters. These tests are applicable to varying components and systems as determined suitable based upon the context of their function within the façade and the materials themselves.

Additional testing measures will be adopted to specifically test Open-State cavity barriers. The Association

for Specialist Fire Protection (ASFP) have developed *Technical Guidance Document – TGD 19 Fire resistance test for ‘Open-State’ cavity barriers used in the external envelope or fabric of buildings* which provides a detailed approach to such tests.

1.3 Equipment

Testing equipment and methodology will vary depending upon the specific testing methodology and the components which are subject to such testing. The following components of equipment are commonly applied within fire testing regimes:

- Specially designed furnace to subject the test specimen to the test conditions;
- Control equipment to enable the temperature of the furnace to be controlled;
- Equipment to control and monitor the pressure of the hot gases within the furnace;
- Frame in which the test construction can be erected and which can be positioned in conjunction with the furnace so that appropriate heating, pressure and support conditions can be developed;
- Arrangement for loading and restraint of the test specimen as

appropriate, including control and monitoring of load;

- Equipment for measuring temperature in the furnace and on the unexposed face of the test specimen, and where needed within the test specimen;
- Equipment for measuring the deflection of the test specimen;
- Equipment for evaluating integrity and for establishing compliance with the performance criteria;
- Equipment for establishing the elapsed time;
- Equipment for measuring the oxygen concentration of furnace gases.

The specific function and combination of each of the above items is set-out within the testing standards and associated procedures themselves and will be described in the sections to follow.

1.4 Test Conditions

To ensure there can be consistency in the results used to ultimately determine the adequacy of test samples against defined performance criteria, it is important that the testing conditions fall within a defined and quantifiable range. The following general conditions are particularly important within such fire testing regimes:

- **Heating conditions** and furnace atmosphere to conform to that given within EN 1363-1 and EN 1363-2 where applicable;
- **Pressure conditions** must be monitored and controlled such that the magnitude of pressure at a defined point in the test is within a specific range of pressure at a prescribed location within the furnace itself;

The above conditions are fundamental for each testing procedure and ensure results may be relied upon in establishing performance under fire loading and that there is consistency in controlled testing conditions between various testing methods.

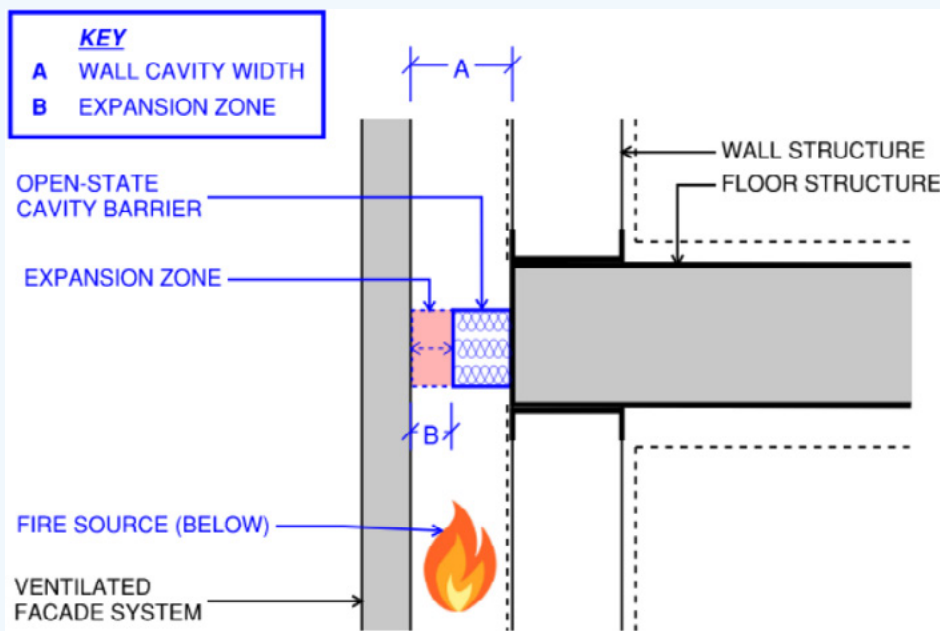

Figure 5.8: Open-state cavity barrier diagram

It is important to note that the performance established through testing is carried out under very specific testing conditions as defined within the associated Standards and as is necessary to form a quantifiable performance baseline to which differing materials and systems may be compared. The test conditions may not be reflective of actual fire conditions nor performance in practice and it is important that this is collectively understood.

1.5 AS 1530.1 Methods for fire tests on building materials, components and structures

1.5.1 Part 1: Combustibility test for materials

AS 1530.1 is used to determine the combustibility of a given material under controlled testing conditions.

The test does not apply to products which are coated, faced or laminated. Where such materials are required for testing, the constituent parts forming the product must be tested separately together with a detailed specification for the sampling and preparation of each specimen.

Materials are determined as combustible or non-combustible within this test. Those which are deemed non-combustible are expected not to burn appreciably even when exposed to severe fire conditions. Combustibility may be defined as follows:

- The mean duration of 'sustained flaming' is anything other than zero;

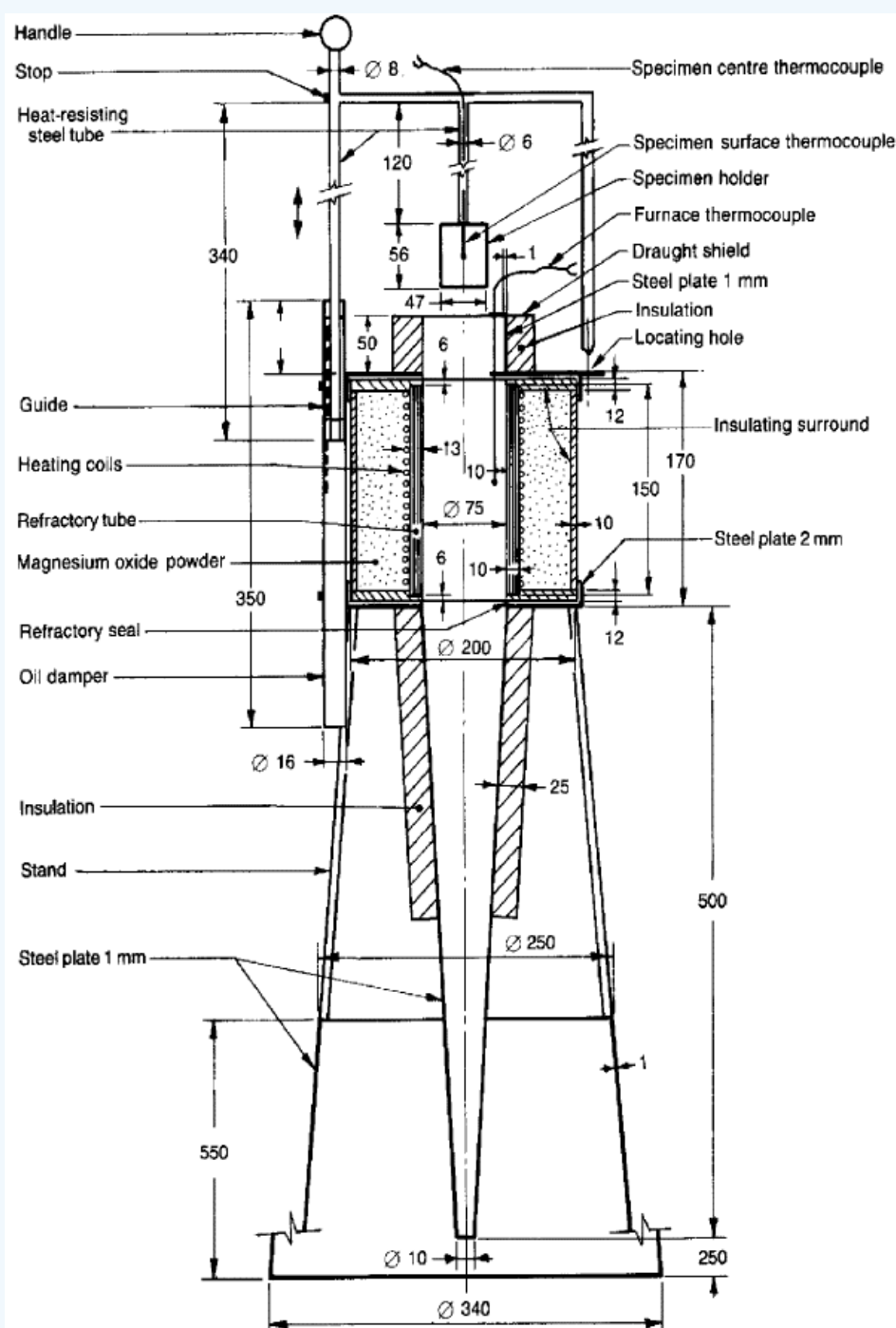

Figure 5.10: Combustibility Apparatus (AS 1530.1)

A4 THERMALLY UNSTABLE MATERIALS The criteria used for evaluating materials (see Clause 3.4) will be used for qualifying materials which may be thermally unstable, i.e. materials that melt or shrink at the test temperatures. In these cases, the information recorded by the specimen thermocouples may not be relevant and regulating authorities may choose not to use the information. In these cases, one or both thermocouples need not be included. Glass fibre and rock or slag fibre insulating materials with similar densities and calorific values and which should be quantified similarly by this test, have been demonstrated to give different results because of the above phenomena.

Figure 5.9: AS 1530.1 - Appendix A - A4

1.5.2 Part 2: Test for flammability on building materials, components and structures

AS 1530.2 testing establishes the flammability index of a given material.

This provides a datum point for performing a fire hazard assessment and is typically used in conjunction with other testing methods within the overarching AS 1530-testing Standard series to inform the overall potential fire hazard of a selected material.

A specimen typically comprises a thin sheet or woven material which is sufficiently pliable to be inserted into the testing apparatus by hand and without special softening treatment which ensures it may be graded according to a flammability index. This test involves the use of an ignited flame applied directly to the base of the test specimen. It is therefore unsuitable for materials which readily melt or shrink when in contact with an open flame. When a material is tested, three key parameters are measured, namely:

1. Speed factor;
2. Heat factor, and;
3. Spread factor.

These key testing factors are collectively used to inform the material grading from which the flammability index is determined for a given material. The testing Standard specifies that “where it is necessary” materials shall be rearranged such that these parameters are established for different material directions and face orientations. The necessity of such additional testing “sets” is dependent upon whether a materials properties differ by direction. Given an isotropic material can be defined as those whose properties remain the same when tested in different directions, it can be surmised that such additional sets may be applicable to those materials which are non-isotropic in nature.

9No. test specimens are required per testing set as defined within the Standard. Should the material behave differently by direction or the surface texture or finish on one face differs to that of the opposite, additional test specimen sets shall be tested to ensure all conditions are captured within the results.

The testing apparatus is setup within a controlled environment consisting of draught-free room or enclosure in subdued lighting. The procedure involves a specimen of defined geometry being mounted on a frame comprising brass rails of light-gauge angle section formed to a slightly convex profile towards the direction of the tested specimen. A dimensional scale of a defined length is installed on one side of the testing apparatus with the specimen's lower end aligned with the base (zero) point of the scale and held in position using lightly tensioned wires connected along locating pins.

A controlled flame is ignited at the base of the specimen using an electric spark. The fuelling agent comprises a defined volume of absolute alcohol which is pre-heat and contained within a trough at the apparatus' base. The mounting frame is inclined from the vertical, and its lower edge is set at a specific height above the centreline of the alcohol trough. The entire assembly is then positioned beneath the centreline flue such that the entirety of the maximum flame height can be viewed at eye level.

Several thermocouples of equal resistance at ambient room temperature are positioned within the flue and connected in parallel to a potentiometer at a defined height above the top of the specimen. With every 6 testing cycles, the interior of the flue, hot junctions of the thermocouples and any residue within the alcohol trough are cleaned before continuing with further tests.

On igniting the flame and commencing the test, the height at the tip of the main body of airborne flame shall be observed and recorded for a maximum period of 160 seconds. In instances that the flame does not reach the 21st scale mark (533.4mm), the maximum flame height is recorded. Conversely, where the flame does reach the 21st scale mark, the time at which this occurs is recorded. The temperature indicated by the thermocouples is recorded at 1-second intervals throughout the test and over a duration of 180 seconds from the point of ignition.

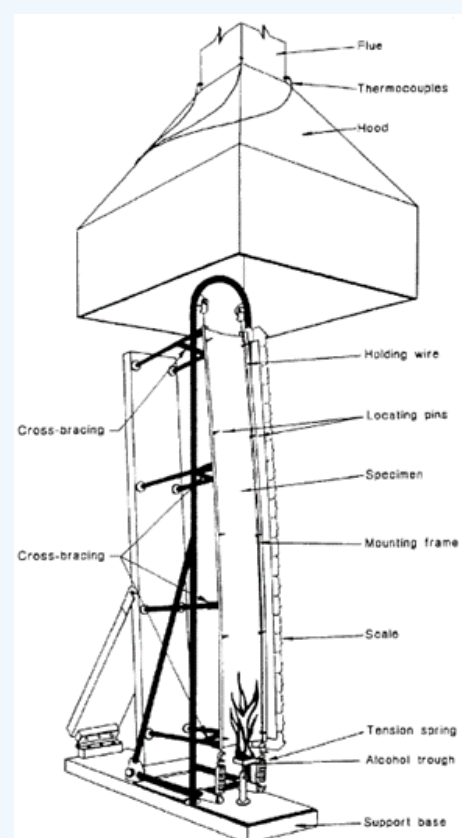

Figure 5.12: Flammability Apparatus (AS 1530.2)

1.5.3 Part 3: Simultaneous determination of ignitability, flame propagation, heat release and smoke release

AS NZS 1530.3 testing is used to determine a building materials and components tendency to ignite, propagate flame, the heat released once ignition has occurred and their tendency to release smoke. This test is predominantly used to establish the potential fire hazard of wall linings during the early growth of fire within a fire compartment. This test is also applicable to “sandwich panel” construction, which is defined as a building component comprising a core which is bonded to a differing facing material on both sides.

Where the NCC stipulates that testing in accordance with AS 1530.3 is required, it must be carried out in accordance with NCC Specification 3.

Similar to the other testing Standards, the results of this test cannot be used to directly assess the fire hazard of a given material or component under all fire conditions, and is instead used to inform this as part of a wider testing regime.

The test involves a specimen being held in a vertical configuration in a plane parallel to a radiant heater. The specimen is gradually moved closer to the heater over a defined period of 20 minutes or until ignition, induced by a pilot flame, occurs. The specimen must be prepared such that it can readily be recognised as representative of the material or component for the use of which it is intended.

A minimum of 9No. testing samples must be available for testing, similar to AS 1530.2. The test requires that surface coatings/finishes and any associated adhesive substances used to attach to the receiving substrates are applied. Where a material or component subject to testing comprises a range of colours, the Standard requires

that a minimum of 2 specimens of the “lightest and darkest” colours of the range are included within the first 6 specimens tested. Should the variability in the results associated with these colours differ by stipulated margins for either ignitability, flame propagation, heat release or smoke release, that a further 3 test specimens shall be tested and used to establish the associated mean performance values based upon all specimens.

It should be noted that for Bonded Laminated Materials (BLM), the CPSP Report 2 specifies additional testing requirements beyond those stipulated within this test Standard are necessary in demonstrating compliance with the Deemed to Satisfy provisions of the National Construction Code (NCC).

The testing rig comprises a thermally insulated timber framed specimen support of defined geometry which is arranged to be facing and parallel to an adjacent gas-fired radiant panel. The support frame is mounted such that it can be progressively moved towards the radiant panel. The timber frame support is fully sheathed with thermal insulation of the side furthest from the radiant panel with the remaining face and edges similarly protected.

A thermally insulated hood and flue is located above the testing rig and functions in collecting the products of combustion. It is important to note that such tests often result in large amounts of potentially hazardous or toxic materials being released into the local atmosphere, therefore, testing operators should be protected accordingly.

The 330x330mm (max.) radiant panel supplied with a controllable gas/air mixture is installed to the opposite end of the pilot flame within the overall testing carriage. The gas is subsequently burnt at the fire-brick surface of the panel. This then functions in heating the porous brick to meet the requirements defined within the testing Standard.

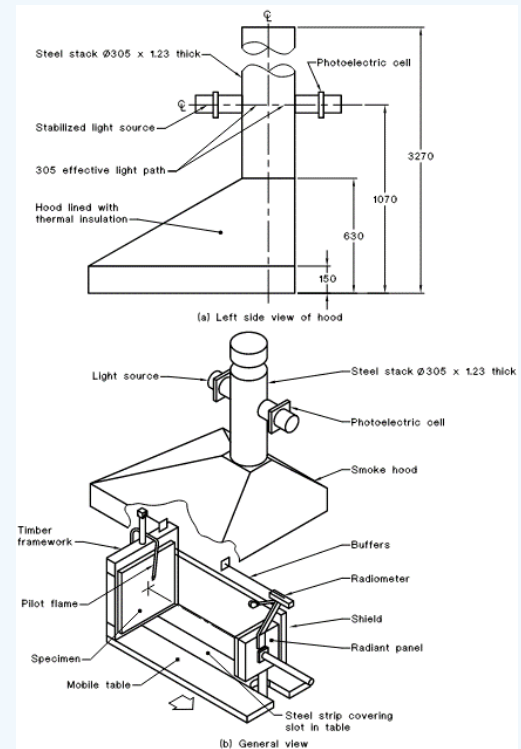

Figure 5.13: Ignitability, Flame Propagation, Heat and Smoke Release Testing Apparatus (AS 1530.3) – Left and General View

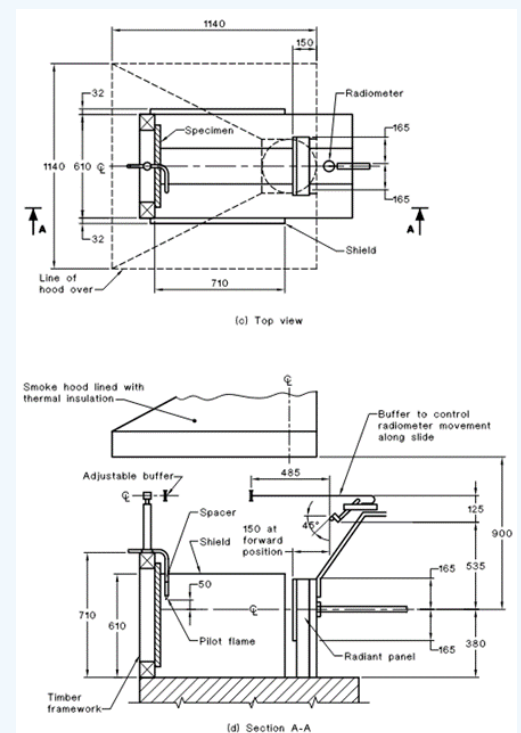

Figure 5.14: Ignitability, Flame Propagation, Heat and Smoke Release Testing Apparatus (AS 1530.3) – Top and Cross-sectional View

A radiometer fitted with a fluorite window providing an angle of complete vision within a defined angular range is mounted on slides above the radiant panel. The radiometer is mounted such that it can move with the specimen carriage during the period of ignition. The pilot flame is located on the opposite end to the radiant panel within the testing assembly.

The testing assembly also comprises a smoke-monitoring system which is mounted on the flue which resides above the testing apparatus. This is a photoelectric cell and monitors the optical density of products evolved from the specimen. A steady light source is located adjacent to the cell to ensure it is not adversely influenced by the linearity of the detector.

Throughout the test, the outputs from the radiometer and the photoelectric detector are monitored in intervals not exceeding 1-second.

The testing procedure itself involves mounting and fixing the specimen to the timber support frame. A number of defined specimen mounting procedures are provided within the Standard for several common materials and these must be used where applicable to a tested specimen. Where there is no equivalence, the testing operator must prepare an appropriate alternative based upon the principles defined within the Standard.

The test itself lasts up to 20 minutes and terminates at the point the specimen is considered to have ignited or if certain radiometer ranges have not been met within defined time frames.

During the test, the specimen is exposed to the source of the radiant heat and moved towards it. A pilot flame is ignited and positioned within close proximity to the specimen and remains at the same distance throughout the test. The distance between the test

specimen and the radiant panel is then gradually reduced such that the distance between the two is defined for corresponding timeframes throughout the test. Once the specimen has ignited, the associated movement ceases and the test concludes.

The data recorded includes the number of specimens igniting and the corresponding time from commencement of the test. The intensity of radiation for the surface of the specimen is also recorded within 1-second intervals, as is the time from the moment of ignition for the radiation intensity to increase by 1.4 Kw/m². The percentage of transmission of light across the flue is also recorded at corresponding time increments throughout the test. The various data points are then used to calculate mean values and standard errors associated with the key performance criteria listed previously and collectively contribute towards informing the fire hazard risk associated with the specimen itself.

It is important to note that a key difference between this test in comparison to AS 1530.2 is that the ignited flame does not make direct contact with the material. This test therefore cannot reliably provide an indication as to how a given material would behave under such an action.

It is also worth noting that materials are often subjected to cleaning treatments throughout their service life. Some treatments may adversely impact upon the fire hazard indices should their be any removal or redeposition of fire-retarding agents contributing to the materials performance as established under testing conditions. As such, it is advisable that testing of a given material is also performed after a number of cleaning treatments, in accordance with the relevant commercial cleaning practice.

1.5.4 Part 4: Fire-resistance tests for elements of construction

AS 1530.4 testing establishes the fire resistance of a given element of construction. This establishes what is referred to as a construction elements Fire Resistance Level (FRL) rating.

In the context of this Standard, elements of construction are defined as either:

- A distinct part of a building constructed by assembling material or materials; or
- A test specimen representing such a part.

Unlike the other testing Standards, the results of this test may be used to directly assess the fire hazard of a given material or component, however, this does not represent a single point of reference representative of a specimens associated hazard risk under all fire conditions and must be used in conjunction with of a wider testing regime as appropriate.

This test involves exposing an element of construction to heat under controlled conditions within a furnace. The furnace is operated to satisfy a specified time-temperature curve, with observations of the performance of the specimen recorded whilst subjected to thermal and, in some instances, physical loading. The times at which failures occur are recorded and used to inform the fire resistance of the element, namely: Fire Resistance Level (FRL).

The Fire Resistance Level (FRL) may be described as a grading period and is established during this test. The FRL is separated into 3-components, namely:

1. Structural adequacy;
2. Integrity; and
3. Insulation.

The testing Standard provides detailed guidance on a wide range of construction elements including both structural and non-structural items, as well as elements pertaining to services.

Project Remediate requires closed-state cavity barriers to be tested in accordance with AS 1530.4 with an alternative testing regime used for open-state cavity barriers.

The test records several key performance indicators which are collectively used to inform the FRL rating, including:

- Temperature of the furnace and that of the element(s) providing a separating function;
- Pressure within the furnace;
- Time elapsed throughout the test – used to inform all collected data;
- Deflection (movement) – observed movement of the specimen;
- Received total heat flux – the rate at which heat energy passes through a given surface; and
- Integrity – the ability of an element to resist the passage of flames and hot gases from one space to another.

The total heat flux measurement requires thermocouples to be carefully positioned to ensure the validity of the test relative to the given specimen. In conjunction with the sponsor, the testing operator shall identify any bespoke or key features of the specimen and introduce additional thermocouples if necessary to ensure an accurate representation of the construction element is captured within the test.

The testing apparatus varies depending upon the particular construction element being tested. In the context of façade applications, the walls providing a vertical separating element is of particular interest. A vertical separating element may comprise solid masonry, prefabricated or framed wall assemblies – each of which are

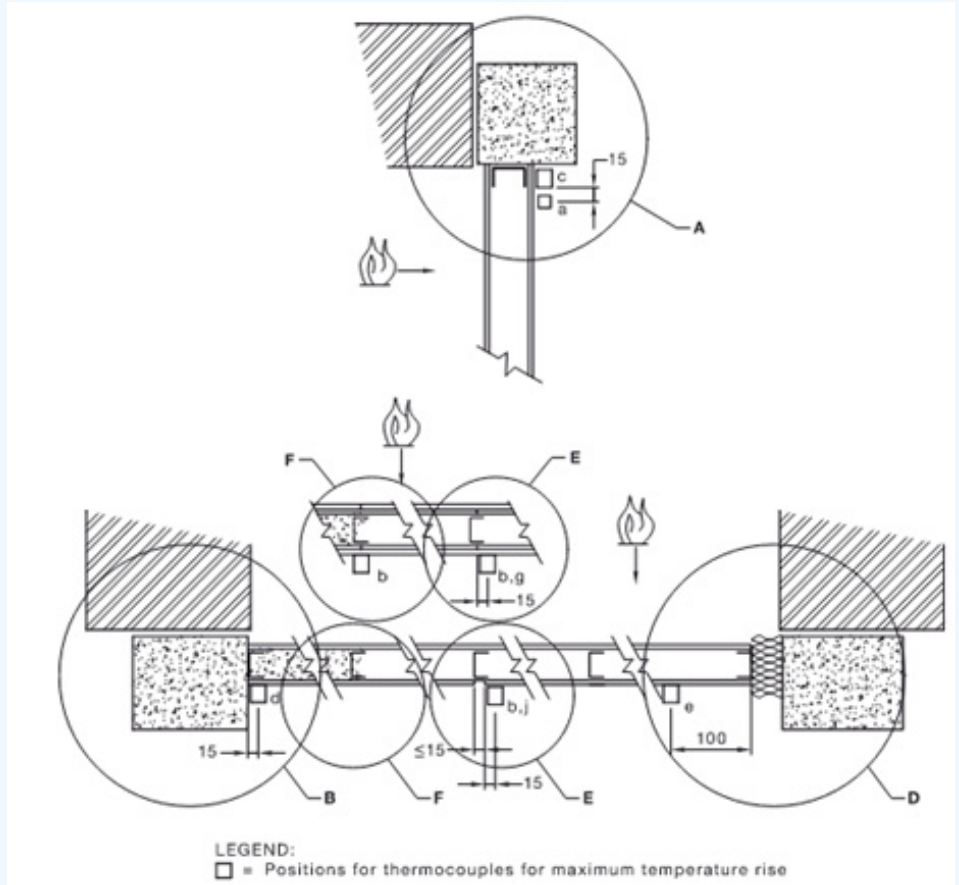

Figure 5.15: Typical configuration of thermocouples – Metal framework w/ horizontal linings (AS 1530.4)

configured differently depending upon their construction and their function as a loadbearing or non-loadbearing item.

Typical to each test configuration is the positioning of the specimen between non-combustible construction within an insulated furnace environment. The heat is applied from one side only, with the average temperatures recorded on the unexposed face using multiple thermocouples as defined within the Standard. There are limitations around the locating the thermocouples which preclude them from being positioned at thermal bridges, joints, junctions and through connections. The temperature within the wall assembly may also be recorded by carefully locating thermocouples without causing damage to the specimen itself.

The testing procedure involves the furnace temperature varying throughout the test following a

predetermined fluctuation related to time. Throughout the test, observations are made in relation to the specimen behaviour and, in particular, its structural adequacy, integrity and insulation – each of which are used to inform the ultimate FRL rating.

The structural adequacy component involves recording the deflection of the specimen following commencement of heating, as well as any dislodgement or detachment of any part, collapses or excessive deflections beyond those outlined within the Standard and any other factor which is perceived as impacting upon the structural adequacy.

The integrity component relates to an elements ability to provide a separating function. The observed behaviour relates to any presence of cracks, fissures, other openings or relevant occurrences observed through the testing regime.

The insulation component relates to the performance when transferring radiant heat between surfaces of an element which, again, provides a separating function. The temperature of the unexposed face is recorded at time increments not exceeding 1-minute throughout, with the emitted radiant heat flux measured to suit.

Additional observations must be recorded by the test operator, and these may not be reflective of a criteria of performance but more so an occurrence which may create hazards or impair upon the performance in some capacity. This could include several indicators such as cracking, fusing, colour changes, spalling, melting and similar. It is important that the test data records all such occurrences and this data is described and detailed within the subsequent reports, as necessary.

It is important to note that the specimen must be representative of the overall construction element for its intended function, therefore, must include horizontal and vertical joints, stiffeners and similar provided these are integral to the elements function in practice. It is important to note that all loadbearing wall elements must be constructed with the vertical edges unrestrained for this test.

1.6 Technical Guidance Document (TGD) 19 - Fire resistance test for 'Open-State' cavity barriers used in the external envelope or fabric of buildings

Technical Guidance Document (TGD) 19 is used to evaluate the fire resistance of the 'Open-State' cavity barriers.

The method was developed by the Association of Specialist Fire Protection (ASFP) who are a UK-based trade association who provide leadership in the area of passive fire protection. The purpose of this

test is to measure the ability of a representative specimen of an 'open-state' cavity barrier to resist the upward spread of fire. This test is of particular concern given the tendency for fire spread between one part of a building through the wall cavity within the cavity zone formed between the rear of the external envelope and the inside face of the backing wall structure. This fire spread is predominantly upwards in trajectory and can propagate rapidly should there be a lack of effective cavity barriers installed.

The testing method involves a specimen being subjected to defined heating and pressure conditions. The regime of testing is contained within a separate European Standard, namely: *EN 1363-Fire resistance tests*, which stipulates the requirements around setting-up the testing equipment and the methods of monitoring performance during testing.

Similar to the overarching fire testing procedures previously described, the use of a furnace is key critical in performing this test. The furnace is designed to use liquid or gaseous fuels and is capable of heating an element or elements of differing types as necessary to appraise the performance of the individual element.

In the instance of cavity barriers, a single (1No.) test specimen representative of a given construction is used. The furnace applies a heat to the underside of element with a clear distance of 200mm (min.) between the specimen itself and the heat source at all times. Reflecting the gap required for cavity air flow, there is a gap between the specimen and the non-combustible construction representing the external cladding material.

The key points to be noted by those seeking to demonstrate compliance against this Technical Guidance Document should be understood as follows:

- The test does not relate to a façade system, nor does the assembly reflect one. Façade systems comprise numerous elements and components which are not captured within such a test. As such, the results do not reflect how any given façade system may respond during a fire-event, and serve only in verifying how effective a tested cavity barrier is in responding to such an event;
- To determine how a sample component may perform within a specific façade system, a large-scale test would be necessary. Such testing would not be appropriate for a programme involving the replacement of cladding, given the numerous variables within the existing construction.

Different set ups are prescribed within TGD-19. The differences between each relates to the configuration of materials surrounding the tested specimen and a common feature of each set-up involves the use of blockwork (non-combustible) as representative of the external envelope. This blockwork must satisfy a minimum density requirement which varies depending upon the use of either autoclaved aerated concrete ($650\text{kg/m}^3 \pm 200\text{kg/m}^3$) or normal weight concrete ($2,400\text{kg/m}^3 \pm 200\text{kg/m}^3$). This non-combustible surface serves as the surface to which the test specimen expands towards and seals against. The clear distance between the sample material and this surface is defined by the test sponsor and shall be set to a maximum of 25mm. It should be noted that any decrease of this dimension may be permissible, however, such reduction must then correspond with the maximum air gap reflected in application.

The following test setup represents the typical configurations which are adopted during testing:

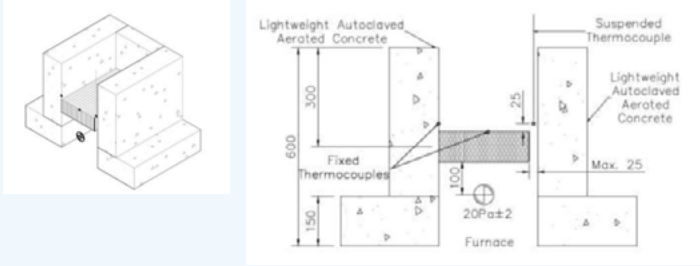

Figure 5.16: Test set up 'A' - Block to non-combustible material

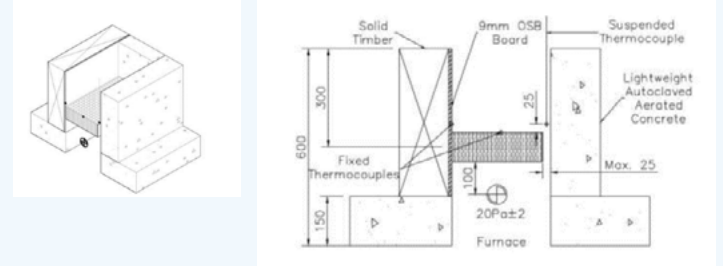

Figure 5.17: Test set up 'B' - Timber frame to non-combustible material

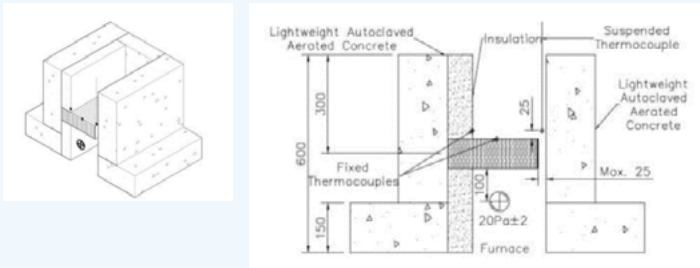

Figure 5.18: Test set up 'C' - Block with interrupted insulation to non-combustible material

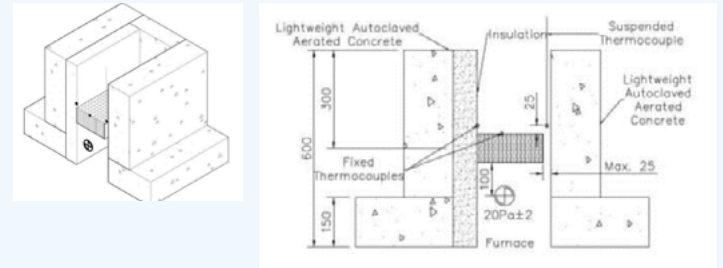

Figure 5.19: Test set up 'D' - Block with uninterrupted insulation to non-combustible material

The performance criteria in this test are evaluated using cotton wool pads, gap gauges and operative monitoring of the test specimen for evidence of sustained flaming. These parameters may be outlined as follows:

- **Effective closure of the 'open-state' cavity barrier**
 - Time taken for the barrier to close – this must be within 5-minutes or otherwise be deemed to have failed the test
- **Insulation**
 - Transmission of heat through the test construction must not raise the thermocouple temperatures of the unexposed surface of the test specimen more than 180 K above the initial temperature
- **Integrity**
 - Prevention of cotton wool pads from igniting during the test

The test involves applying a controlled temperature within an environment where the pressure can similarly be controlled. The test specimen response to this heat is then recorded by measuring the gap between the specimen and the non-combustible material. The time taken for the cavity barrier to close (seal) is critical, and this is achieved by visually observing the point at which there is no visible gap apparent between the construction element and the non-combustible boundary element. There is also a limitation on the thermocouple temperature relative to the initial ambient temperature prior to commencement of the test.

The test requires the monitoring and recording of any sustained flaming which may occur on the unexposed surfaces of the tested specimen, including any parts of construction which are located above the cavity barrier test specimen.

As outlined within the CPSP Report 1, for Project Remediate, all open-state cavity barriers must achieve a Fire Resistance Level (FRL) as follows:

- **Minimum 30 minutes' integrity (E 30), and**
- **Minimum 15 minutes insulation (I 15)**

For open-state cavity barrier products to be deemed suitable for use within Project Remediate, testing reports must be provided demonstrating compliance against Technical Guidance Document (TGD) 19.



Recommendations for Project Remediate

Evidence will be required to demonstrate compliance against the performance criteria associated with all the adopted products (various).



Recommended Reading

Fire safety guideline for external walls: A guide for high-rise construction in Australia [CSIRO External Wall Safety Guide](#)

Specification of Masonry Anchors [AEFAC Technical Note](#)

Technical note: Site testing guidelines – Vol 1: General [Site-testing-Vol1 \(aefac.org.au\)](#)

HILTI commentary on-site testing and masonry fasteners – [On-site Testing - Ask HILTI](#)



Recommended Viewing

External Recommended Viewing Resources

 **Play video** Hose Testing AAMA 501 2 Water Intrusion Testing (Leak Inspection) – YouTube

 **Play video** AS 1530.1 Combustibility test – YouTube

 **Play video** Test apparatus for flammability of material to AS1530.2 – YouTube

Product Traceability

6

Chapter 6:

Product Traceability

The NSW Government has announced a collaboration with KPMG to develop a world-first construction tool to differentiate between trustworthy and non-trustworthy buildings. The Building Trustworthy Indicator (BTI) combines data points about the participants (who), construction materials (what) and certificates/documents (how) involved in the building development across design, construction, and commissioning. Regulators, Banks, and Insurers can leverage the tool to gain insight into the construction process adhered to both for individual assets and the broader built environment. This enables the identification of trustworthy assets and allows for more informed financing and risk management decisions.

The NSW Government is developing the Building Trustworthy Indicator (BTI), a world-first construction trustworthiness tool to assist with residential building compliance.

BTI is a market-led digital product that enables differentiation between trustworthy and non-trustworthy built assets and brings transparency to building construction processes. A means to differentiate between two built assets will enable informed consumer choices, differentiations for developers, builders and trade practitioners and empower insurers, financiers and regulators to leverage data in their decision-making processes.

The NSW Government has taken the lead in developing this digital technology in partnership with KPMG to drive transparency and lift standards in the construction industry.

BTI will assist regulators in identifying potential “risky” practitioners and facilitating the comparison of compliant and non-compliant buildings which supports the Office of the Building Commissioner’s focus on improving the quality of residential apartment buildings and restoring trust in the construction industry through the Construct NSW strategy. NSW Fair Trading, SafeWork NSW and other agencies will also have access to the BTI to assist them with identifying defective work and products.

BTI provides a measure of trustworthiness at both the design stage (Trustworthy As Designed) and final construction stage (Trustworthy As Built). The preliminary BTI score provided at the design stage indicates the trustworthiness of the design after a Construction Certificate (CC) has been issued. At this stage of the building development cycle the who, what and how of the design process is measured. The trustworthiness of the final construction building is indicated by measuring the who, what and how of both the design and construction process.

BTI collects data across five key building elements that have the greatest impact on quality and safety of a building. Overlaid with the data captured against these key building elements, BTI captures information on the:

Materials (What) used in the building and their adherence to appropriate standards and regulations

Key members (Who) of the construction team (developer, builder, trade contractors, designers) and uses an established measure of player trustworthiness (the iCIRT Rating) to determine their historical performance.

Certificates and documents (How) across design, construction and commissioning of the building that demonstrate adherence to appropriate standards, regulations and relevant QA processes.

The BTI tool will be implemented as part of the NSW Project Remediate program to create a single source of truth for replacement façade systems.

Implementation of Building Trustworthy Indicator (BTI) Technology

BTI uses blockchain technology to ensure the immutability of data captured by the tool. This ensures that the integrity of all data collected and its respective digital history is maintained.



Recommendations for Project Remediate

1. Product and design compliance certificates must be provided for products being used in Project Remediate
2. The compliance certificates must address all criteria defined within the Building Trustworthy Indicator (BTI) scheme before being accepted for use on Project Remediate.



Sustainability in Remediation



7

Chapter 7: Sustainability in Remediation

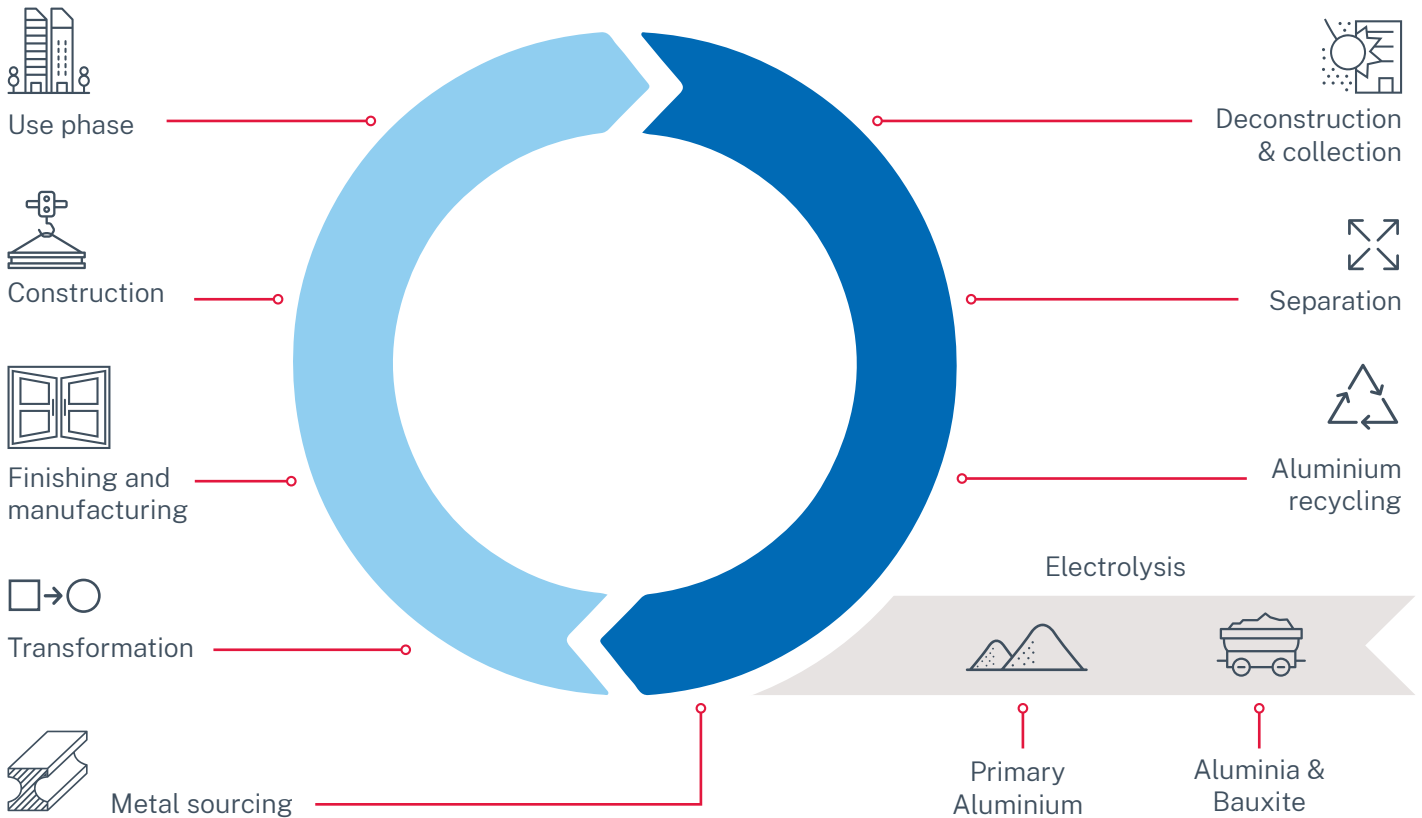

Figure 7.1: Life cycle of composite panels

The philosophy of Environmentally Sustainable Development is well ingrained in the property industry and designers are striving to incorporate these principles into building designs through initiatives such as Greenstar.

Design for disassembly, re-use and recycling is often a provision made theoretically in the design process. When a building is reclad, however, these goals are often seen to be cast aside with the removed materials disposed of as general solid waste and subsequently sent to landfill.

Project Remediate seeks to implement practical, cost effective initiatives to optimise the recycling of the removed materials.

In replacing the cladding of approximately 200 buildings, it is estimated that approximately 350,000m² of façade cladding will be removed.

The resource recovery percentage will be dependent on the scope of the cladding remediation works. Hansen Yuncken have undertaken a study considering a whole wall system and associated cladding panels as being replaced. They then collated this data and quantified the equivalent mass associated with both recyclable and non-recyclable content, as set out within the table to follow.

Product	Mass Recyclable (kg/sqm of wall)	Mass to land fill (kg/sqm of wall)
ACP Panels	7.15	0.15
Sealant and Backing Rod		0.5
Aluminium Extrusions	2	
Subframing	2	
Sarking		0.5
Plastic Packers	0.5	
Insulation		6
Total	11.65	7.15

In summary, a re clad project could generate approximately 18.8kg of waste per 1m² and approximately 11.65kg would be recycled (cladding panels, metal framing and fixings and plastic sundries). 7kg would go to landfill (insulation, sealant and backing rod).

By weight, approximately **63%** would be recycled in instances where cladding panels and associated façade elements are required to be removed and disposed of. The percentage of recycled content will improve to **98%-99%** in instances where only cladding panels are required to be removed and disposed of.

A number of specialist cladding recyclers, industry supplier and waste recyclers were approached to discuss the options for recycling ACP panels and other general waste generated through the program.

It was determined that the cost to recycle versus the cost to send to landfill for the ACP panels was approximately the same value (\$6.00/m²).



Figure 7.2: Aluminium Recycling Plant

Recycling of ACP

The investigation identified a number of key elements in the process of recovering and recycling ACP panels.

Material Storage and Handling

The storage of removed cladding panels will be dictated by the site logistics and project requirements. The ACP recycling contractors can pick up removed cladding panels as pre-arranged by the project team. This may be once or twice a week by truck or more frequently using smaller vehicles if required. Typically, 400m² of cladding panels are picked up per load. This is equivalent to a 9m³ bin, subject to the extrusions attached to the panels.

Panels are placed directly into skip bins before being collected by specialist bin trucks. This requires the bin location to be accessible for large vehicles and requiring no other specialist loading equipment on site.

Recycling Process

The recycling process was consistent across a number of recycling contractors with minor variations:

- The cladding panels are removed from the façade by the Remediation Contractor. They are carefully packed into a skip bin, with the Contractor adopting a bulk packing method serving to maximise the skip storage volume to reduce the associated transportation demand. These are loaded and transported by truck to the ACP Recycling Contractor’s facility.
- Upon arriving at the facility, the materials are weighed and prepared to go through the processing plant. The processing involves a combination of shredding, crushing and grinding.
- The output is finely milled granules. These granules are separated and sorted into the relevant elements.
- These granules are bagged and passed onto the relevant external recyclers.

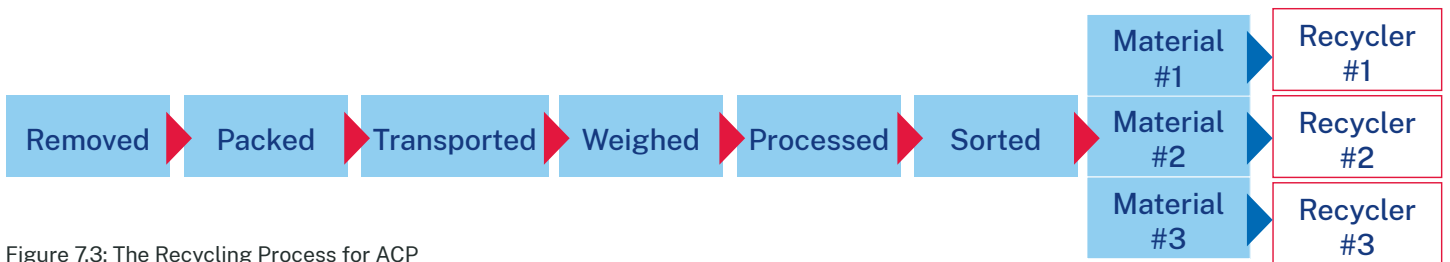

Figure 7.3: The Recycling Process for ACP



Figure 7.4: The recycling output is finely milled granules

Fire Safety

All ACP Recycling Contractors are conscious of the increased fire load and risk associated with ACP and have Fire Risk Management Plans in place at their processing facilities. Measures in place include:

- Moving materials through the facility as quickly as possible
- Reviewing work processes to ensure there is no risk of ignition
- Controls measuring temperature of materials
- Regular maintenance of fire safety equipment
- Detailed evacuation procedures
- Dispersing stockpiles safely across the site.

Material Tracking

The recycling contractors interviewed provide reports that demonstrate the chain of custody from the moment the material is collected from site to identifying the end products that the recycling granules are remanufactured into. These reports are certified by independent industry bodies.

Offshore Recycling

All the material is retained onshore. None of the local recycling contractors expressed any incentive to ship materials offshore.

Sustainability in practice!

Through the sustainable alternative waste management methods deployed as part of the Project Remediate, one of the 1st projects to be delivered resulted in recycling 4.6 tonnes of materials. This is the equivalent of 206 wheelie bins worth of landfill space savings! The water savings from that project amounted to around 1/10th the volume of an Olympic sized swimming pool, and the Greenhouse benefits represented the equivalent to removing either 6.5 cars worth of emissions from our environment, or the impact of approximately 18 average households' energy usage per year!

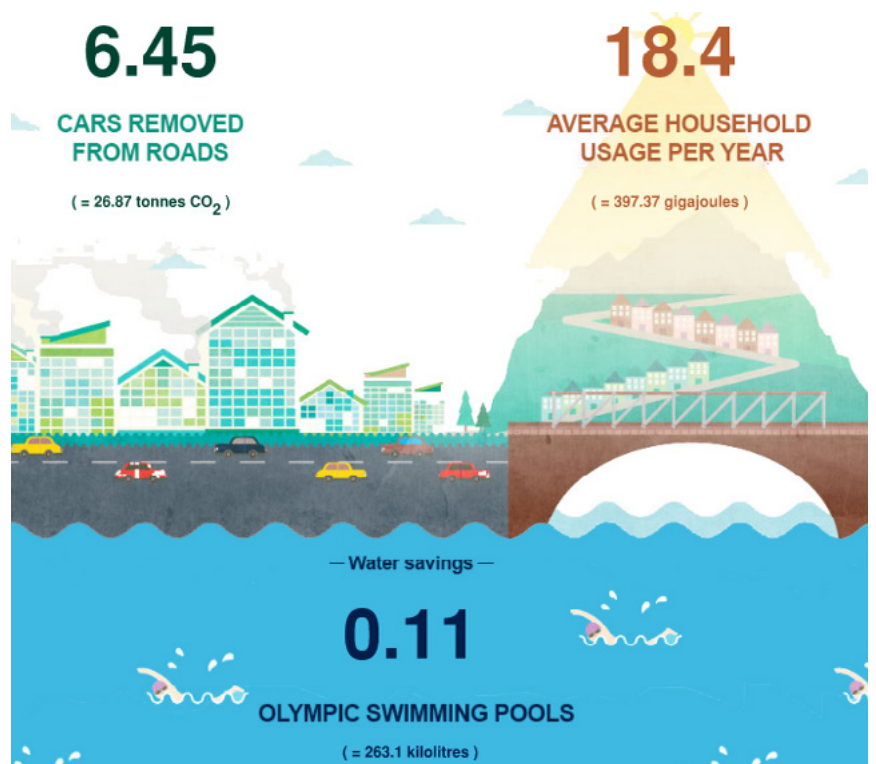



Recommendations for Project Remediate

From the investigations undertaken by Hansen Yuncken, the following strategies are to be implemented for Project Remediate:

1. Where possible, demolition material is to be recycled in preference to placing in landfill
2. A program wide strategy is to be implemented. A partnership is to be formed with selected collection and recycling contractors
3. Site management and planning is to consider the requirements for material storage and measures to reduce the fire load and risk
4. Designers are to consider the end-of-life management strategy with the intention of minimising energy consumption during any future deconstruction phase.



Recommended Reading

Architecture & Design: Is this the solution to our cladding disposal woes? <https://www.architectureanddesign.com.au/news/ecoloop-fairview-cladding-disposal>



Recommended Viewing

NSW Government Media

 [Play video](#) Aluminium Composite Panels Recycling Plant | ACP Separation Machine

 [Play video](#) ACP Panels Recycling Plant In Australia: Aluminium Plastic Separation Machine

Certifications on Completion



Chapter 8:

Certifications on Completion

Project Remediate will ensure compliance of all aspects of the building process including material composition, manufacture of components, design of wall systems and installation of all elements. This is to be achieved through an assurance process which requires proof of compliance through test certificates by accredited laboratories and declarations by Registered Design and Building Practitioners.

Generic Façade Types

The façades to be replaced comprise 3 distinct elements:

1. Cladding
2. Subframing
3. Wall structure.

They also often incorporate several critical features including:

- Weatherproofing barrier
- Fire-rated spandrel panels to protect opening between floors
- Fire-rating of complete wall due to proximity of a fire source feature
- Insulation.

Cladding

The recladding process will comprise the removal of existing cladding including sealants at interfaces and replacement with material which has been approved by the CPSP. Currently these are:

- Solid Aluminium
- Solid Metal Sheets
- Fibre cement
- Non-combustible Cement Render
- Engineered Ceramic Cladding Systems (ECCS)
- Bonded Laminated Materials (BLM).

Subframing

Cladding panels are fixed to a subframe using mechanical fasteners. The subframe is typically one or two layers of top hats which are supported by the existing wall structure. These are generally formed from pre-galvanized sheet, however, where located in regions of high corrosivity, the top hats must be formed from aluminium or similar material which has a high corrosion resistance.

It may be possible to utilise the existing framing. The designer must assess the structural adequacy and remaining design life of the entire system. It is unlikely, however, that the subframing will satisfy the geometrical requirements unless the existing system has been mechanically fastened.

It should be noted that cement render is applied directly to a masonry or concrete structural wall after removal of any existing subframing.

Wall Structure

This will be an existing element and may be constructed from a number of different materials including

- Solid or core-filled concrete blockwork
- Hollow concrete blockwork
- Solid brickwork
- Hollow (extruded) brickwork
- Aerated Autoclaved Concrete blocks or panels
- Solid reinforced concrete
- Metal frames (e.g., galvanized steel stud).

The consultant must assess the structural adequacy of the wall to resist the anticipated loads.

Weatherproofing

Weatherproofing is provided by one of the following:

- Solid concrete
- A masonry wall backed by a drained cavity
- A solid block wall proven to be waterproofed
- A layer of sarking material within the build-up of the wall system.

The triage consultant must identify this element and advise whether weatherproofing system should be incorporated into the reclad works.

Fire-rated spandrel panels

The wall system may be required to provide vertical spandrel separation between openings. The triage consultant must assess the effectiveness of the existing system to provide the required separation. If not present or determined to be inadequate, a fire-resistant wall construction must be installed.

Fire-rated walls

As above, the existing building approval may require certain external walls to have a specific FRL. The triage consultant must identify any such requirement and confirm the adequacy of the existing walls.

Insulation

Insulation may be required to be added to the wall system to compensate for a reduction in the insulating properties of the replacement cladding. It may also need to be installed as part of remedial works if insulation has been omitted from the wall system or if combustible insulation is required to be replaced.

Certifications required

To provide assurance of the compliance of the new and existing wall systems, the following aspects must be addressed.

Product or System Certifications

Products and systems utilised in the reclad work must demonstrate compliance with the relevant standards referenced in the NCC and provide evidence of the required performance parameters. These are to be provided by the product manufacturer or supplier. Key elements are listed below. Other elements may be introduced by the designer for specific projects or as additional products are approved by the Cladding Product Safety Panel (CPSP).

Certifications of the existing system

The consultant must:

- Certify the structural adequacy of existing wall systems to resist the loads specified by AS 1170 Parts 1, 2 and 4
- Identify any combustible or non-compliant elements within the wall system.

Certification of new designs

New designs will be developed under the framework Design and Building Practitioners Act.

Designs will need to be declared by a registered façade consultant and certification confirming that the new elements comply with the requirements of the applicable National Construction Code (NCC) used at the time.

The designer may require on-site testing to support the design certification. This may include:

- Verification of capacity of masonry anchors
- On-site hose testing of joints.

The Design Practitioner is to undertake interim and/or final inspections against their design to ensure correct installation and integration with façade framing.

Products and Systems standards

Product	Material Standard	Compliance evidence	Fire Standards	Compliance Standards	Structural Standards	Compliance Evidence	Other Standard	Compliance Evidence
Steel sub framing (light gauge)	AS 1595	Compliance Certificate	AS 1530.1 –Non Combustible	Not required CPSP approved	AS 4600 ¹	Prototype testing or Declared Design	Durability Galvanized coating mass to AS 2312	Supplier Warranty
Aluminium sub framing	AS/NZS 1866	Compliance Certificate	AS 1530.1 –Non Combustible	Not required CPSP approved	AS 1664 ¹	Prototype testing or Declared Design		
Solid Aluminium	AS/NZS 1734	Compliance Certificate	If coated surface AS 1530.3 Spread of flame not greater than 0	Test Certificate	AS 1664 ¹	Prototype testing or Declared Design	Metal finishing to AS 3715	Supplier Warranty
Compressed Fibre Cement Sheeting	AS/NZS 2908	Compliance Certificate	AS 1530.1 –Non Combustible	Not required CPSP approved	AS 4040	Prototype testing		
Solid Metal Sheets	AS 1562	Compliance Certificate	AS 1530.1 –Non Combustible	Not required CPSP approved	AS 4600 ¹	Prototype testing or Declared Design	Minimum coatings to AS 1397	Supplier Warranty
Sarking < 1mm thick	AS 4200	Compliance Certificate	AS 1530.2 Flammability Index not greater than 5	Test Certificate	AS 4040	Prototype testing	Permeability testing to ASTM E96 ⁵	Test Certificate
Sarking > 1mm thick	AS 4200	Compliance Certificate	AS 1530.1 –Non Combustible	Test Certificate	AS 4040	Prototype testing	Permeability testing to ASTM E96 ⁵	Test Certificate

Installation Certification

- Certification that the works have been constructed in accordance with the design drawings and any requirements arising from any method of complying with the relevant performance requirements (e.g., Codemark certifications) for wall systems
- Certification that the fire barriers have been installed in accordance with manufacturer's recommendation
- Certification that pull-out tests undertaken on masonry anchors achieve required capacities specified by the design consultant
- Certification that any site water testing of façades specified has been undertaken in accordance with the specification and that all interfaces have passed.

Other requirements of the Fire Order

In addition to the above, the Fire Order may impose conditions that may require certification to confirm compliance.

Product Warranties

9

Chapter 9:

Product Warranties

It is recommended that the following warranties be specified for Project Remediate. These are in addition to product certification and testing.

Typical Product Warranty Periods

Warranty Item	Warranty Period (Years)
Render	N/A
Compressed Fibre Cement Panel	10
Solid Aluminium Panel	15
Solid Metal Panel	15
Engineered Ceramic Cladding Systems	20
Bonded Laminate Panel	15
Exterior Paint	10
Sarking	10
Top Hats/Sub-Framing	10
Insulation	20
Cavity Barrier	25

In addition to the warranty periods noted, the following list sets out the preferred warranty conditions to be adopted for Project Remediate:

- Be for a period of at least 10 years
- Be in favour of the owner of the building (eg an owners corporation) where the product is supplied
- Not contain onerous clauses on an owner concerning maintenance, record keeping and making claims
- Not contain exclusions which make the warranty illusory or difficult to enforce
- Be a warranty not just for the cost of the defective product but also include all costs associated with removing and disposing of it and replacing it
- Be subject to the laws of NSW and be enforceable in courts in NSW
- Be given by an entity that has a presence in Australia.

The above conditions are non-exhaustive and the program welcomes manufacturers exceeding these targets.

It is important for those involved in the Program to be conscious that product manufacturers often provide a warranty on the proviso that their product is used as part of a wider overall system comprising specific components or products. It is therefore incumbent upon those responsible for the specification and procurement of products within this Program to ensure the warranties are directly applicable for the project-specific application and overall system construction.



Recommendations for Project Remediate

1. Warranties to be a minimum of those listed above
2. Suppliers' guidance on specification, preparation, and installation to be sought by the relevant parties in order to maximise the working life of the associated product(s)
3. Manufacturers are to seek to achieve the product warranty conditions set out above as a minimum target.

Fire Cavity Barriers

10

Chapter 10: Fire Cavity Barriers

The replacement cladding systems implemented for Project Remediate include ventilated and drained rainscreens. Experience has shown that the cavity behind external cladding can promote the spread of flame between floors due to a chimney effect. While the current NCC specifies materials to fill voids between fire-rated elements, it does not yet specify the treatment of ventilated cavities. Building Codes in other countries such as the UK have recently introduced specifications for such façade elements.

Project Remediate recognises the benefits of the use of cavity barriers and aims to implement international best practice for the design solutions in this program.

Cavity Barriers

Cavity barriers form a fire and smoke containment system that prevent the spread of fire and smoke through cavities within a building cladding system. They are not to be confused with fire stops which fill the voids between fire-rated elements and must satisfy different performance requirements.

Cavity barriers are categorized as either open-state or closed-state.

Open-state cavity barriers allow ventilation within a cavity under cold (normal) conditions and close the cavity under fire conditions. Such cavity barriers commonly comprise intumescent materials that can be activated at elevated temperatures (typically about 180–200°C). The intumescent materials continuously expand and seal the cavity gaps whilst remaining in place and withstanding the fire conditions for a considerable period.

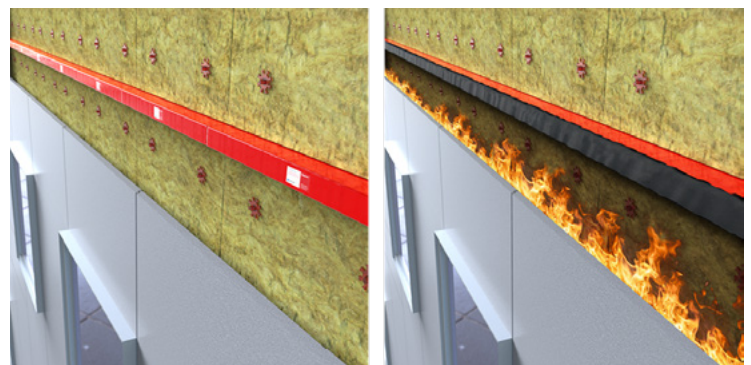

Figure 10.1: Open-state cavity barrier before and after activation

Ventilated cavities require vertical air circulation under normal conditions whilst also allowing moisture to drain from the cavity. Horizontal cavity barriers are, therefore, required to be open-state.

Open-state cavity barriers are not tested vertically and, therefore, can only be used horizontally.

There is no relevant Australian standard for open-state cavity barriers. Project Remediate is to follow the provisions set out in the UK building code: *The Building Regulations 2010: Approved Document B - Fire Safety (2019+A2: 2022)*.

Within this document, the provision of cavity barriers describes their functional requirements as follows:

To reduce the potential for fire spread, cavity barriers should be provided for both of the following.

- a. *To divide cavities.*
- b. *To close the edges of cavities*

In addition, this document discusses the scenario of the interface against windows (albeit, in the context of replacement). This states as follows:

...it may be necessary to provide cavity barriers around the opening.

This is adopted within the Program and reflects best practice as part of a wider effort seeking to eliminate the risk associated with fire spread within a building envelope's cavity space. The document also specifies where such elements shall be adopted, namely:

Cavity barriers should be provided at all of the following locations.

- a. *At the edges of cavities, including around openings (such as windows, doors and exit/entry points for services).*
- b. *At the junction between an external cavity wall and every compartment floor and compartment wall.*
- c. *At the junction between an internal cavity wall and every compartment floor, compartment wall or other wall or door assembly forming a fire resisting barrier*

The typical locations where cavity barriers may be deployed are presented within the diagrammatic illustrations to follow. The preceding commentary is intended to provide further context into the background of the cavity barriers and may be useful in the context of the Program, given such construction methods are not currently adopted within the industry, however, function as a critical component as part of Project Remediate.

Closed-state cavity barriers completely fill the cavity void at all times and are compressed between the inner surface of the outer wall element and the outer surface of the inner wall element. This type of cavity barrier can be used where they do not adversely affect the required cavity ventilation, such as closing the edges of an opening.



Figure 10.2: Closed-state cavity barrier

Closed-state cavity barriers can be tested using Australian Standards. To maximise the locally available products which can be used, the materials used closed-state barriers are required to conform to AS 1530.1 and AS 1530.4.



Figure 10.3: AS 1530.4 Testing Rig

Cavity Barrier Specification for Project Remediate

Scope

This specification proposes the minimum requirements for cavity barriers for ventilated cavities, which are common features observed in remedial cladding projects, and of which are not required under the BCA Deemed-to-Satisfy Provisions.

The specification only applies to the external walls subject to cladding rectification works under Project Remediate. The scope of the relevant building works, and the level of BCA compliance are understood subject to determination and acceptance by the relevant authorities.

Application

The requirements of this specification does not override nor replace applicable BCA compliance and regulatory requirements including, but not limited to, the following:

- i. External walls required to have an FRL in accordance with the BCA and building regulations
- ii. Construction required for spandrel protection in accordance with BCA clause C2.6(a)(iii)
- iii. Performance Solution (or Alternative Solution) requirements applicable for the relevant building or building parts
- iv. Construction methods verified in AS 5113 fire tests and assessed by BCA Verification Method CV3, as considered acceptable by the relevant authorities
- v. Other applicable BCA Deemed-to-Satisfy Provisions, including the BCA clauses C1.1, C1.9, C1.13, C1.14, C2.6, and the BCA specifications C1.1 and C1.13.

Locations

Cavity barriers are to be provided at all of the following locations as a minimum requirement:

- i. At the edges of cavities, including around openings (such as windows, doors)
- ii. At the junction between an external cavity wall and one of the following fire-resisting elements:
 - a. Every floor
 - b. Every fire compartment wall
 - c. Every internal fire-resisting bounding wall between two sole occupancy units and/or between a sole occupancy unit and a common area
 - d. Every fire-resisting wall required by the BCA Deemed-to-Satisfy Provisions
 - e. Every fire-resisting wall required by an existing Performance Solution (also known as Alternative Solution) when no cavity protection is required.

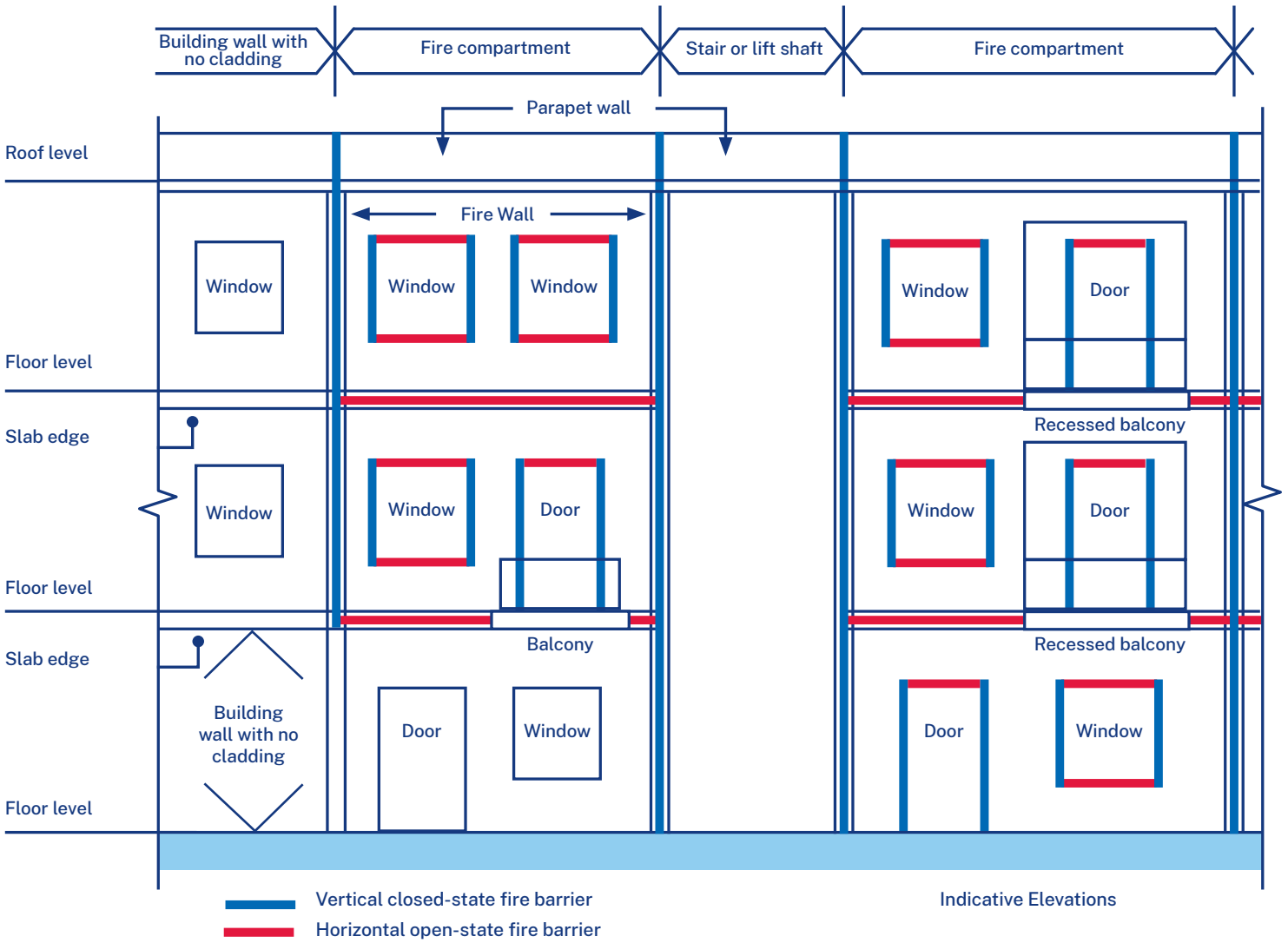

Figure 10.4: Locations of cavity barriers

Figure 10.5 illustrates accepted typical arrangements of cavity barriers for different external walls with ventilated cavities. The cavity barriers in red are open-state and horizontal types.

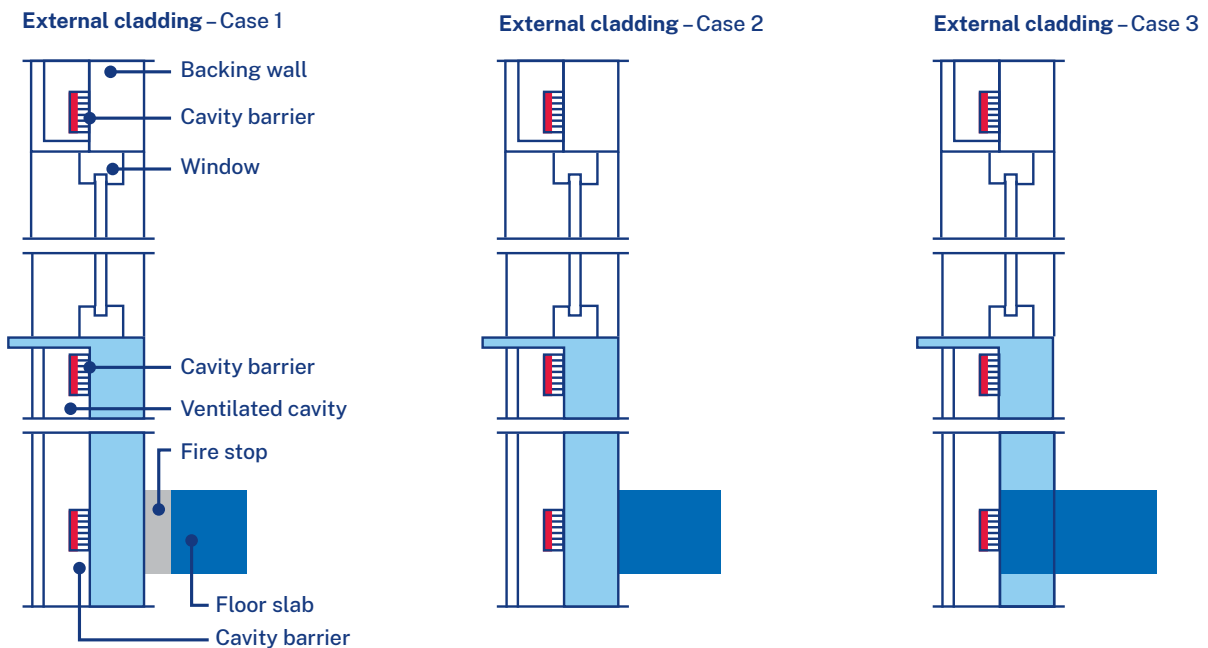

Figure 10.5: Examples of installation of horizontal and cavity barriers

Fire Resistance Requirements

Cavity barriers must achieve the required fire resistance levels (FRL).

FRLs for cavity barriers must be demonstrated through fire testing by manufacturers in accordance with the following requirements:

Closed-state Cavity Barriers

Have test (or assessment) reports provided by a NATA accredited test laboratory demonstrating the products satisfy AS 1530.1 requirements and having a minimum FRL of -/30/15 in accordance with AS 1530.4:2014.

Open-state Cavity Barriers

Have test reports demonstrating the products have been tested in accordance with ASFP TGD 19, Fire Resistance Test for 'Open-State' Cavity Barriers 2017, to have:

- i. Minimum 30 minutes' integrity (E 30), and
- ii. Minimum 15 minutes' insulation (I 15).

Cavity-edge Cavity Barriers

Cavity-edge cavity barriers are to be provided at the edges of cavities, including around openings (such as windows, doors and exit/entry points for services) within the external walls.

Design and Installation Requirements:

- i. Cavity barriers must be tightly fitted to a rigid construction and mechanically fixed in position
- ii. Cavity barriers should be installed, so their performance is unlikely to be made ineffective by any of the following:
 - a. Movement of the building due to subsidence, shrinkage or temperature change, and movement of the external envelope due to wind
 - b. During a fire, the collapse of services penetrates the cavity barriers, either by the failure of the supporting system or through degradation of the service itself (e.g., by melting or burning)
 - c. During a fire, failure of the cavity barrier fixings
 - d. During a fire, failure of any material or construction to which cavity barriers abut.
- iii. Service installations must not penetrate the cavity barriers or be formed within the cavity of the cladding system itself. This applies to service installations such as cables, ducts and pipework
- iv. Cavity barriers must be designed and installed in accordance with the product tested conditions, manufacturers' specifications and used for the product approved applications only

- v. Cavity barriers must be designed and installed to suit the weatherproofing and façade ventilation requirements
- vi. Cavity barriers are to be continuous. Vertical framing should be curtailed above and below the barriers.

As per Approved Document B (British Building Regulations, 2019), solid metal cavity closers are deemed an accepted form of construction for use within the cladding cavity. In the context of Project Remediate, solid metal cavity closers are considered to be acceptable for use around openings (only) provided ventilation and drainage requirements are satisfied.

Where solid metal cavity closers are adopted, it is important that durability is maintained. The specified metal material must be compatible with project specific climatic zone with any exposed edges or drilled holes treated with anti-corrosive surface coating or treatments to protect the cavity closer within what is a wet environment.



Figure 10.6: Cavity barriers are to be continuous

Typical Design and Installation Process

- i. The design and installation of cavity barriers require essential product information, including at least the following:
 - a. Product datasheets
 - b. Test/assessment reports
 - c. Designed and tested applications
 - d. Manufacturer's installation methods as tested conditions
 - e. Product compliance and warranty statements, including satisfying this specification.

- ii. The cavity barrier design process for Project Remediate shall follow the following procedure typically:
 - a. Obtain or prepare reasonably accurate architectural plans for the existing building
 - b. Prepare cavity barrier elevation plans showing all required locations
 - c. Select appropriate cavity barrier products based on this specification, the product information, the installation locations, the façade designer's plans and specifications
 - d. Prepare a complete set of cavity barrier specifications, including locations, types, product models, and installation requirements
 - e. Provide design declarations or design certificates stating that cavity barriers and associated works have been designed in accordance with this specification, relevant test reports, the relevant Australia Standards and applicable Performance Solutions.
- iii. The cavity barrier installers are to install cavity barriers in accordance with the cavity barrier plans, specifications and the manufacturer's product installation methods
- iv. The installation of cavity barriers is to be inspected and certified by a Registered Design Practitioner (Façade) or a Registered Certifier (Fire Safety)
- v. The design and building practitioners are to engage the technical representatives from the product manufacturers or suppliers to provide product training, inspection and certificates to ensure the validity of the product warranty and fit-for-purpose
- vi. The design practitioner is to undertake interim and/or final inspections against their design to ensure correct installation and integration with façade framing.

Note that the use of open-state cavity barriers is not explicitly covered under NCC 2019 and that a method of complying with the Performance Requirements will be necessary on a project by project basis in lieu of compliance with AS1530.1. As discussed separately, internationally developed alternative tests directly applicable to this form of construction are available and are endorsed for use as part of this Program.

Maintenance Requirements

Maintenance is to be undertaken in accordance with the requirements of the suppliers. Any necessary details to allow this to occur are to be incorporated into the design.

Cavity barriers are to be added to the building's Fire Safety Schedule via the Fire Order process and certified annually as part of the ongoing Annual Fire Safety Statement (AFSS) process. The annual fire safety inspection is to confirm that no alterations to the façade have been made which might adversely affect or disturb the cavity barriers. Should such alterations be identified, an inspection of the potentially affected barrier should be undertaken.

Technical Paper: Curtain Walls and the use of Cavity Barriers

The Pattern book has been developed for typical external wall systems encountered in Class 2 buildings which are constructed in place with a structural wall spanning from slab-to-slab. The structural wall is usually constructed from masonry, concrete or light-gauge metal stud. The cladding for this type of façade construction is typically site fixed to light-gauge metal or aluminium top hats and due to the presence of a continuous cavity is formed between the outside face of the structural wall and the external cladding. This has been identified as a fire hazard as there is the potential for the cavity to act as a chimney, as discussed within the preceding chapters. To mitigate this hazard, Project Remediate has specified that for closed-and open-state cavity barriers are to be installed vertically and horizontally behind the external cladding respectively.

The Program has also identified instances where curtain walling façade systems have been found to have elements of combustible cladding. Curtain walling systems deviate from in-place floor-to-floor façade systems in that they are typically formed as interlocking modules and, importantly, do not contain a continuous cavity between levels due to the presence “stack joints” at or near floor levels. These joints prevent an open and continuous cavity, and this shall be discussed further in the discussion to follow.

Recladding of curtain walls provides a different challenge. The installation of cavity barriers can cause significant complications to the performance of the façade system and be difficult to install.



Discussion

Curtain wall façade systems are fabricated off site and installed as discrete modules. Usually these modules are one storey in height with a horizontal joint (a “stack joint”) located above the floor slab.

The modules are generally in the order of 1.5 to 2.4m wide. The structure of the panels is generally formed using aluminium sections and connect together via interlocking “split” mullions.

The wall panels are typically “top-hung” systems which are suspended from the slabs and located outboard of the slab edge. The gap between the inside face of the panel and the slab edge is sealed to prevent smoke spread and is often filled with fire stopping material.

Glazing, solid cladding panels and insulation is installed in the factory between the main framing elements. A cavity is formed behind the cladding and the insulation. This cavity is usually sealed in a curtain wall and the overall system construction enables this to be ventilated. The width of this cavity is normally in the order of 50 to 75mm, however, there have been instances observed as part of the Program where high-rise residential developments contain large, discrete box-type feature façade elements which are fixed to the framing elements forming the curtain wall systems. This may not be a typical occurrence for Class 2 buildings, however, it is considered worth clarification for the purposes of informing the industry as to the applicability of the proposed rectification measures relating to the prevention of fire spread within buildings involved in the Program.

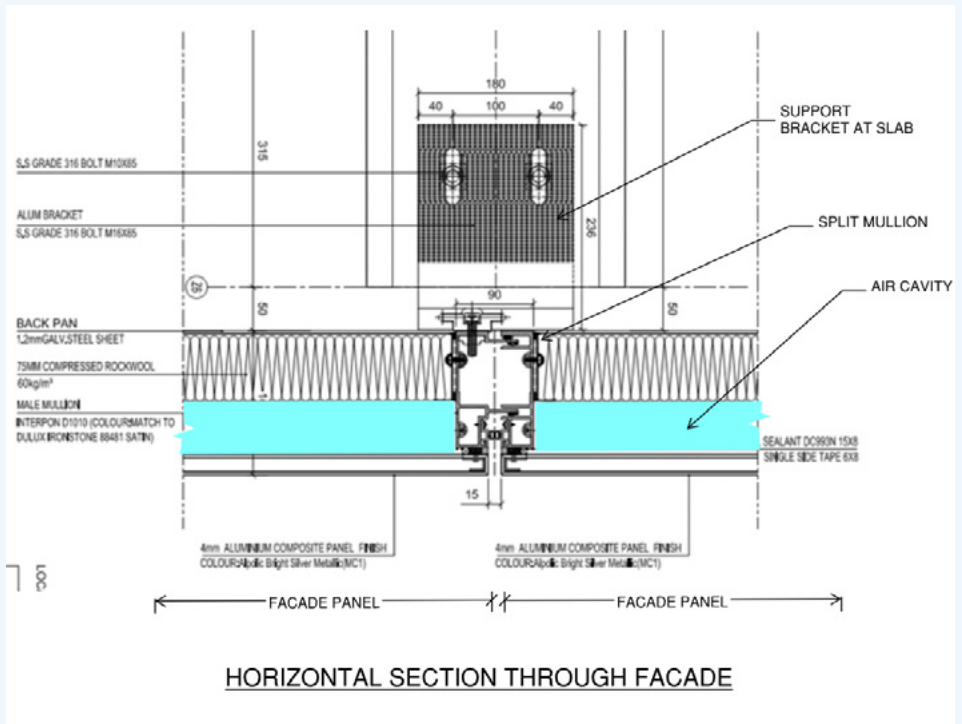
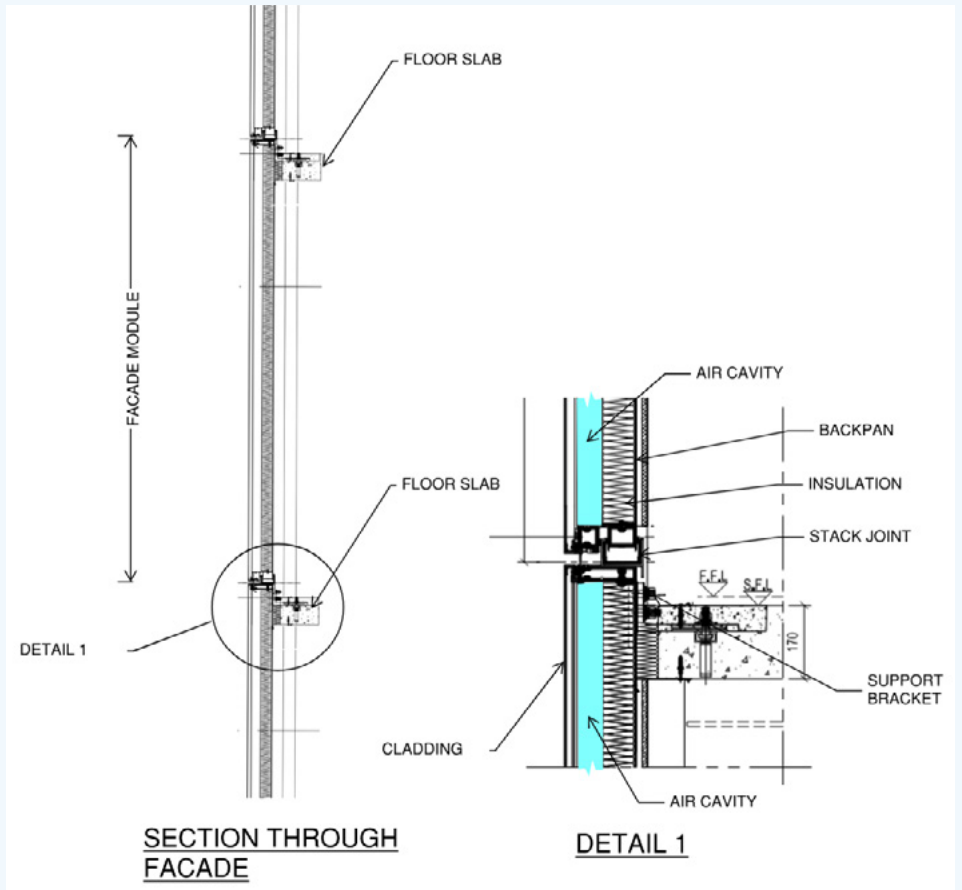

For the situation presented within the preceding detail excerpts, the installation of cavity barriers would require significant modification of the existing sub framing to allow for the installation of continuous cavity barriers at the floor level similar to the method deployed for façades built in-place floor-to-floor discussed separately.

In many instances the inside face of each curtain wall unit is sealed with a metal backpan.

For the purposes of informing the extent and application of the proposed measures endorsed as part of the Project Remediate, the following should be noted by participants of the Program:

- The cavity behind the cladding is highly segmented and is discontinuous vertically and horizontally. As such, the chimney effect which presents the significant risk to other forms of façade construction is not considered to be similarly present within this type of façade construction. Given the segmentation inherent to such a system, the chimney effect inherent to unsealed cavities cannot be readily formed.
- Given the construction typically comprises predominantly glazed assembly within non-combustible aluminium framing elements, the volume of potential fuel load within the curtain wall system is deemed to be low.
- The installation of continuous cavity barriers at slab edges

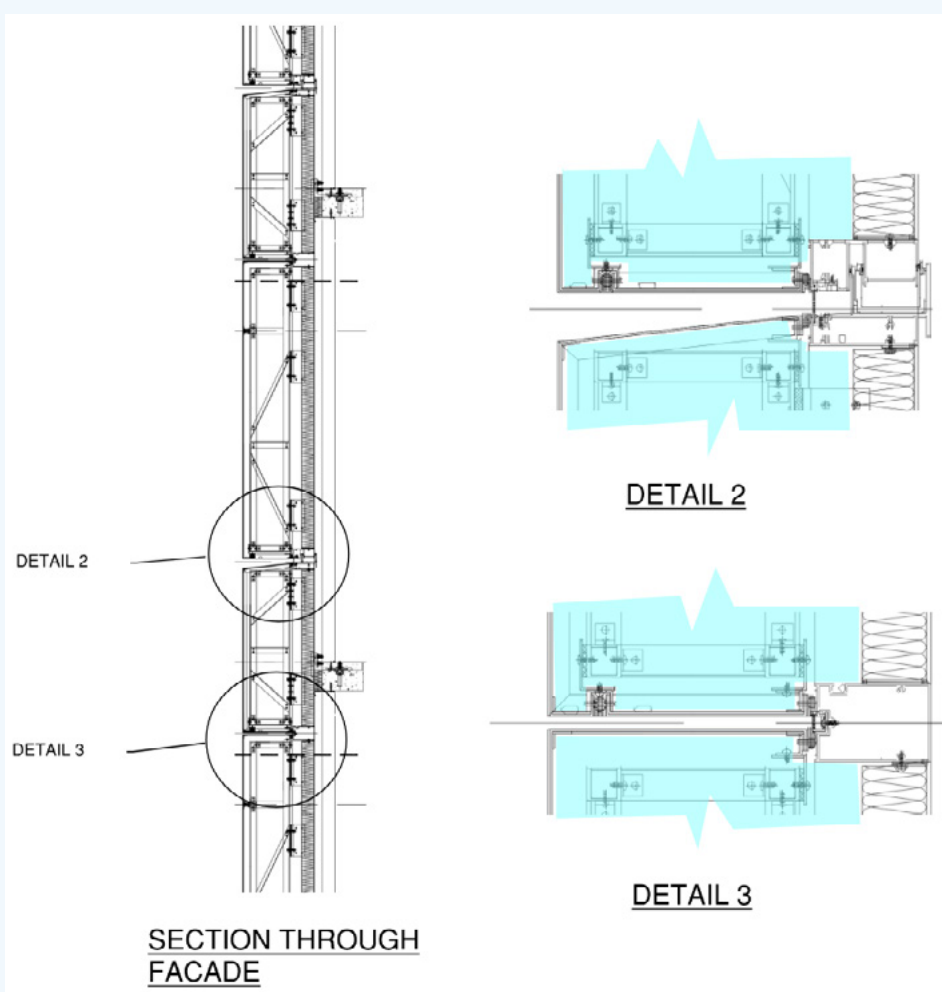

would require significant modification to the structural framing in most situations scenarios. Such an exercise would incur significant expense to participants in the Program and should only be adopted if deemed necessary for the safety of building occupants.

- The inside lining of the curtain wall is generally comprises a non-combustible galvanized steel backpan. Such materials

generally satisfy the *Deemed-to-Satisfy (DTS)* requirements associated with the NCC and are therefore not considered as an inherent fire safety risk.

Given the cost and the potential damage to the wall system there is a little benefit to justify the installation of cavity barriers.

Recommendation

Where a curtain wall is to be reclad and the following criteria are met:

- i. cavity behind the cladding is not continuous due to the presence of horizontal stack joints, and;
- ii. there are regular vertical joints between the façade modules which block the cavity, and;
- iii. a non combustible backpan is present on the inside face of the curtain walling system

cavity barriers need not be installed in the space behind the external cladding.



Recommended Reading

HM Government 2019, Approved Document B, Edition 2019, The Building Regulations 2010 https://assets.publishing.service.gov.uk/government/uploads/system/uploads/attachment_data/file/937931/ADB_Vol1_Dwellings_2019_edition_inc_2020_amendments.pdf

Association for Specialist Fire Protection (ASFP) 2017, ASFP Technical guidance document -TGD 19, Fire resistance test for 'open-state' cavity barriers used in the external envelope or fabric of buildings <https://www.thenbs.com/PublicationIndex/documents/details?Pub=ASFP&DocID=321452>

Association for Specialist Fire Protection (ASFP) 2016, ASFP red book –Fire-Stopping: Linear joint seals, penetration seals and cavity barriers, 4th ed <https://asfp.org.uk/store/viewproduct.aspx?id=19909164>

RICS 2021, Cladding for surveyors, 1st ed, London <https://www.rics.org/globalassets/rics-website/media/news/news--opinion/fire-safety/cladding-for-surveyors-supplementary-info-paper-1.pdf>



Recommended Viewing

External Recommended Viewing Resources

 **Play video** SIDERISE Installation Guidance: RH & RV Cavity Barriers for Rainscreen Cladding (2019) –YouTube

 **Play video** ASFP: Cavity barriers & cladding (2013) –YouTube



Condensation Management

11

Chapter 11:

Condensation Management

Condensation is an event which reveals the presence of water vapour in the atmosphere in the context of façade construction. If this occurs within the wall cavities and moisture is unable to escape, significant issues can arise, in particular, health and safety (including mould growth and durability), corrosion of metal and degradation of elements which are not designed to be wet such as plasterboard.



Figure 11.1: Black mould growth in a wall cavity due to poor ventilation and condensation on inside face of cladding

The ABCB has produced a publication “Handbook – Condensation in Buildings” which comprehensively describes the mechanisms and considerations for façade design and detailing.

NCC Requirements

NCC 2019 requires the ‘risks associated with water vapour and condensation to be managed to minimise their impact on the health of the occupants’. The DTS provisions are set out in Part F6 and applies to Class 1 buildings, sole-occupancy units (SOUs) of Class 2 buildings, and Class 4 parts of buildings.

Climate Zones referenced in this chapter are as defined by NCC 2019 Volume 1 Schedule 3 Figure 2 and Table 2.

F6.2 Pliable building membrane

- a. Where a pliable building membrane is installed in an external wall, it must:
 - i. comply with AS/NZS 4200.1; and
 - ii. be installed in accordance with AS 4200.2; and

- iii. be a vapour permeable membrane for climate zones 6, 7 and 8; and
 - iv. be located on the exterior side of the primary insulation layer of wall assemblies that form the external envelope of a building.
- b. Except for single skin masonry and single skin concrete, where a pliable building membrane is not installed in an external wall, the primary water control layer must be separated from water sensitive materials by a drained cavity.

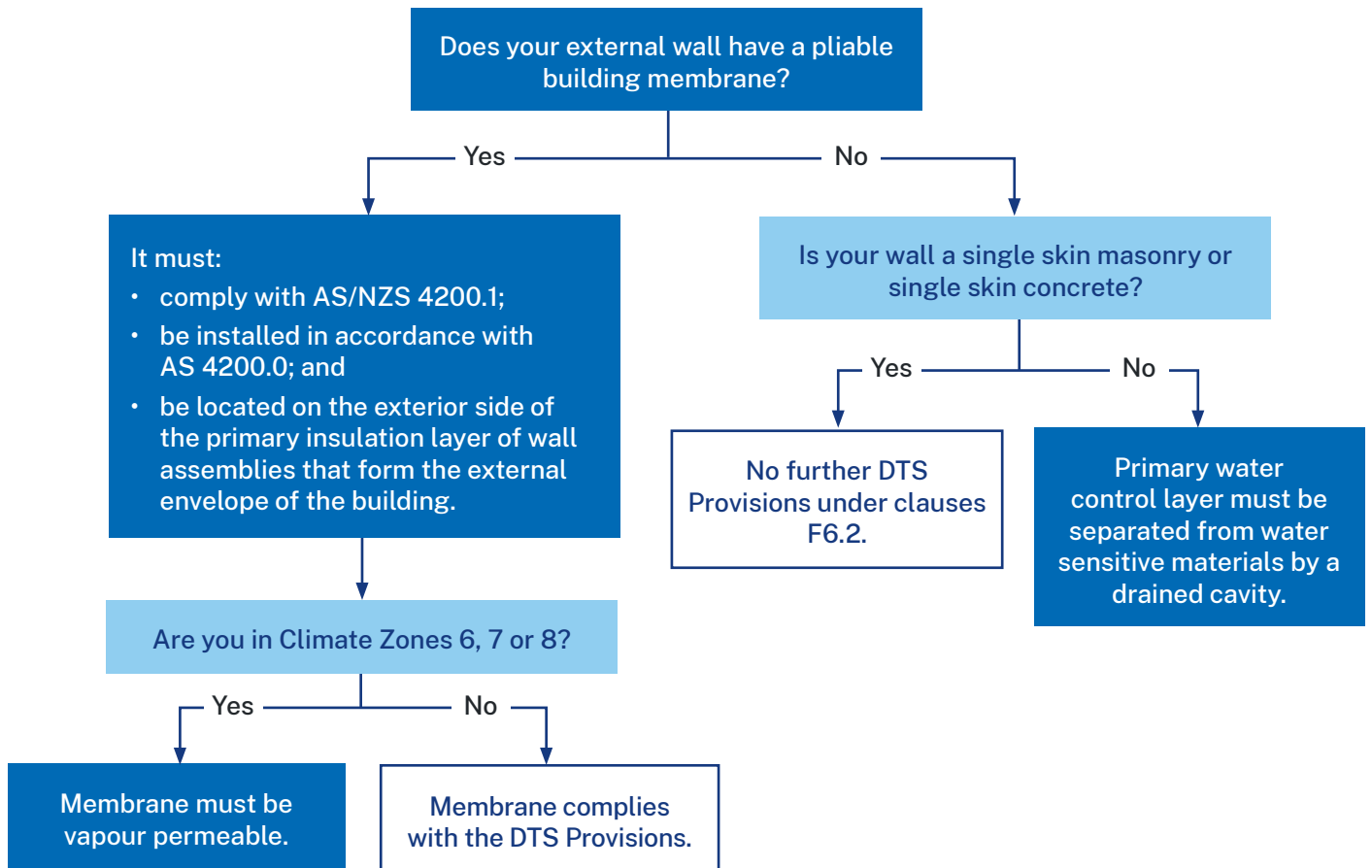

Figure 11.2: NCC 2019 - News - New condensation requirements in NCC 2019 (<https://ncc.abcb.gov.au/news/2019/new-condensation-requirements-ncc-2019>)

Wall Assemblies with Pliable Building Membranes

When using a pliable building membrane, there are two key points to consider:

1. Is a pliable building membrane required?
2. Does the pliable building membrane need to be vapour permeable?

A pliable building membrane may be required for different reasons such as weatherproofing purposes, energy efficiency (i.e. part of the total R-value of the envelope) or managing condensation. In some instances it's also common practice to install a pliable building membrane where it's not strictly required. As an example, a builder or designer might include a pliable building membrane as an extra layer of weatherproofing/insulation or to protect water sensitive materials. In this situation, whilst well-intentioned, there is risk of inadvertently creating issues associated with water vapour and condensation.

When thinking about whether a pliable building membrane needs to be vapour permeable or not, the manner in which the water vapour moves through the building envelope must be considered. A pliable building membrane is often placed on the external side of water sensitive materials. This may prevent water vapour from escaping the building envelope, creating a situation where condensation accumulates on the internal side of the pliable building membrane (where the water sensitive materials are located). Subclause F6.2(a) of NCC 2019 Volume 1 addresses this issue by requiring that pliable building membranes be installed in cooler climate zones 6, 7 and 8 are vapour permeable membranes, regardless of why they have been installed.

Wall Assemblies without Pliable Building Membranes

Single skin masonry and concrete walls are exempted from requiring either a cavity or a pliable building membrane by subclause F6.2(b) of NCC 2019. However, it should be noted that weatherproofing of these wall assemblies may still be necessary as they are then required to function as the primary water control layer.

A reverse brick veneer construction with no cavity is not considered 'single skin masonry'. Therefore, it would require either a pliable building membrane or a drained cavity separating the primary water control layer from water sensitive materials in order to satisfy the condensation management DTS Provisions.



Recommendations for Project Remediate

Identify wall construction

The designers must identify the wall construction through the triage investigation process and understand the existing weatherproofing mechanisms. A study of the hygrothermal gradient through the existing wall should be undertaken. Software such as WUFI assist in this calculation and will identify where the dew point will occur in a wall build-up. The designer will then need to determine whether the condensation can escape from the wall. The design team should identify any existing shortcomings in the wall design that should be rectified and be reported to the owners corporation at the 30% design presentation.

For walls with cladding supported by light weight framing

A building membrane should be installed. It is recommended that any new membrane for Project Remediate be vapour permeable in accordance with AS 4200.1 to minimise the risk of condensation.

If an existing non-combustible building wrap is in good condition in Climate Zone 5 then it need not be replaced.

All wall wraps in Zone 6 should be assessed and replacement considered if the wrap is not vapour permeable.

For walls with cladding supported on masonry or concrete

For the walls of sole occupancy units, the integrity of the wall should be assessed and if there is doubt as to its ability to act as a waterproof barrier, install a vapour permeable membrane.

For common areas, the walls should be similarly assessed.

Membrane Types

Client (BCA Zone)	Guidance on Vapour Control	Performance and Category
Warm-Humid, or Tropical climates (Zone 1)	Where vapour flow is typically inward, such as where the building is air-conditioned for cooling, the membrane should function as a vapour barrier.	Vapour Barrier – Class 1 or 2
Temperate or Hot-Dry (inland) climates (Zones 2, 3, 4, 5)	These climates have varying diurnal and seasonal temperature changes that can affect the direction of the water vapour flow. In most cases a vapour permeable membrane outside the insulation is recommended to avoid creating a moisture trap, allowing drying in either direction. Where a high level of thermal insulation is used, a high degree of permeability may be required, and in some locations a vapour barrier is required. Expert guidance based on local experience should be sought.	Vapour Permeable or Vapour Barrier Class 2, 3 or 4 as required
Cold climates (Zones 6, 7, 8)	Where there is a strong tendency for outward migration of vapour and a high risk of condensation, vapour permeable membranes should be installed on the cold, external side of the insulation ¹ .	Vapour Permeable Class 3 or 4

¹ The use of a Class 3 membrane such as Rigid Air Barrier may not be sufficient in some cold climates. If a Class 4 membrane cannot be used, a solution may include the use of a material to the interior side of the insulation that acts as a vapour barrier, e.g., a Class 1 or 2 membrane or a vapour sealed plasterboard lining coupled with a mechanical ventilation solution. Seek expert advice prior specifying systems for these regions.

Climate Zones

Project Remediate will encounter buildings in climate zones 5 and 6.

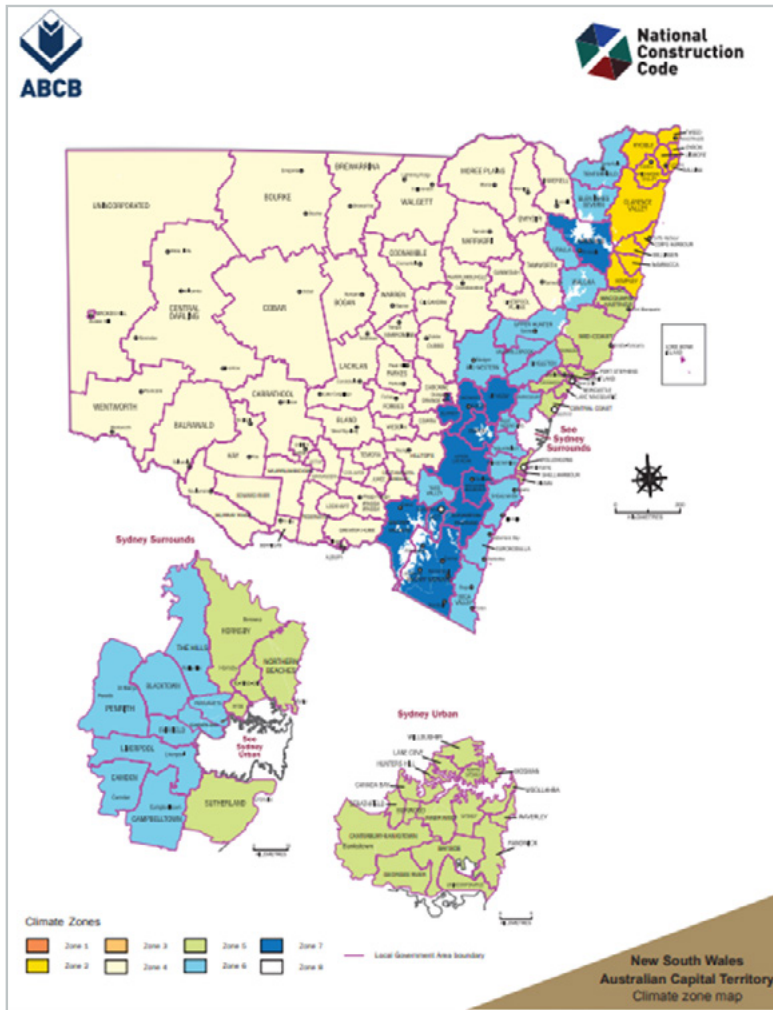

Figure 11.3: NSW and ACT Climate zone map

High wind pressure zones

For Medium to High rise buildings, the wind pressures in the wall cavities need to be considered when selecting the waterproofing barrier. Flexible sarking is generally limited to ultimate limit state wind pressures up to 2.5 kPa. Above this pressure, rigid air barriers (RAB) should be considered.

National Construction Code (NCC) 2022 Implementation

NCC 2022 Volume One contains amendments to the condensation management methods. The *Performance Requirements* applicable to *condensation and water vapour management* remains consistent between **FP6.1** (NCC 2019+A1) and **F8P1** (NCC 2022), however, significant updates have been introduced with respect to the method in which such requirements may be satisfied in addition to how these may be demonstrated to comply.

A noticeable update relates to the *Verification Methods* **F8V1** (NCC 2022) which prescribe the method under which a condensation management study shall be determined, namely, in accordance with *AIRAH DA07: Section 4.3.2*. NCC 2019 (+A1) had previously stipulated the requirement for modelling to be used to determine condensation and water vapour management performance, however, did not prescribe the assessment method. Therefore, this update functions in providing direction to the industry by prescribing the required determination method to be adopted.

The update in the *Verification Methods* **F8V1** (NCC 2022) also specifies acceptance criteria relating to the mould index. This index must be determined in accordance with the *AIRAH* methodology and specified inputs, and established as not exceeding an upper-bound limit of 3. An upper-bound limit was not apparent within NCC 2019 (+A1) which specified only general performance requirements with consideration of the effects of various environmental actions as well as restricting the locations where moisture accumulation may occur relative to the building envelope and component parts. As such, the revised Clause provides clarity to the industry by establishing the minimum requirements to which performance may be measured in order to control the risk of health impacts for those occupying the affected buildings. The amended Clause providing updated compliance requirements is reflected within the below table:

NCC 2019 (+A1)	NCC 2022
Clause FV6	Clause F8V1
<p>Compliance with Performance Requirement FP6.1 is verified when modelling that assesses the effects of–</p> <ul style="list-style-type: none"> a. indoor and outdoor temperature and humidity conditions; and b. heating and cooling set points; and c. rain absorption; and d. wind pressure; and e. solar radiation; and f. material hygrothermal properties, determines that moisture will not accumulate– g. interior to the primary water control layer within a building envelope; or h. on the interior surface of the water control layer. 	<ul style="list-style-type: none"> 1. Compliance with Performance Requirement F8P1 is verified for a roof or external wall assembly when it is determined that a mould index of greater than 3, as defined by Section 6 of AIRAH DA07, does not occur on– <ul style="list-style-type: none"> a. the interior surface of the water control layer; or b. the surfaces of building fabric components interior to the water control layer. 2. The calculation method for (1) must use– <ul style="list-style-type: none"> a. input assumptions in accordance with AIRAH DA07; and b. the intermediate method for calculating indoor design humidity in Section 4.3.2 of AIRAH DA07.

Deemed-to-Satisfy (DTS) Provisions for condensation management have also been introduced within NCC 2022. There had been no equivalent provisions within NCC 2019 (+A1), therefore, this inclusion represents a significant contribution and directly impacts upon how such *Performance Requirements* may be addressed by the industry.

NCC 2019 (+A1)	NCC 2022
N/A	Clause F8D1
No equivalent Clause	<ol style="list-style-type: none"> 1. Compliance with Performance Requirement F8P1 is satisfied by complying with Deemed-to-Satisfy Provisions F8D2 to F8D5. 2. Where a Performance Solution is proposed, the relevant Performance Requirements must be determined in accordance with A2G2(3) and A2G4(3) as applicable.

Clause F8D3 (NCC 2022) specifies the DTS provisions which must be satisfied in achieving compliance with the *Performance Requirements*. This Clause specifies that pliable building membranes must comply with the Parts 1 and 2 of Australian Standard AS 4200: *Pliable building membranes and underlays* covering both *Materials and Installation* respectively. This Clause defines the acceptable location of the pliable membrane as to the exterior side of the primary insulation layer which, again, provides direction to the industry in ensuring appropriate building envelope' design and detailing measures are adopted to reduce risk to the health of occupants. It is also noted that the minimum vapour permeance permitted for pliable membranes has also now been defined for differing climate zones within **F8D3(2)**. The specified minimum permeance is defined only for climate zones 4 through to 8, with the range varying considerably between a group comprising climate zones 4 and 5 (0143 µg/N.s) to that associated with climate zones 6 to 8 (1.14 µg/N.s). The introduction of Clause **F8D3(3)** also sets a requirement for the primary water control layer to be separated from the water sensitive materials through the inclusion of a drained cavity within the building envelope. It should also be noted that whilst Clause **F8D3(3)** prescribes the separation of the water control layer from the water sensitive materials, it notably excludes this requirement for wall constructions which adopt either single skin masonry or single skin concrete.

The introduction of the *Deemed-To-Satisfy* provisions through Clauses **F8D1** to **F8D5** are considered to be of particular interest to the industry. Given the context of the Pattern Book, the preceding discussion focuses upon Clause **F8D3 External Wall Construction**, as contained within the following table:

NCC 2019 (+A1)	NCC 2022
Clause F6.2	Clause F8D3
<ol style="list-style-type: none"> a. Where a pliable building membrane is installed in an external wall, it must – <ol style="list-style-type: none"> i. comply with AS/NZS 4200.1; and ii. be installed in accordance with AS 4200.2; and iii. be a vapour permeable membrane for climate zones 6, 7 and 8; and iv. be located on the exterior side of the primary insulation layer of wall assemblies that form the external envelope of a building. b. Except for single skin masonry and single skin concrete, where a pliable building membrane is not installed in an external wall, the primary water control layer must be separated from water sensitive materials by a drained cavity. 	<ol style="list-style-type: none"> 1. Where a pliable building membrane is installed in an external wall, it must – <ol style="list-style-type: none"> a. comply with AS 4200.1; and b. be installed in accordance with AS 4200.2; and c. be located on the exterior side of the primary insulation layer of wall assemblies that form the external envelope of a building. 2. Where a pliable building membrane, sarking-type material or insulation layer is installed on the exterior side of the primary insulation layer of an external wall it must have a vapour permeance of not less than – <ol style="list-style-type: none"> a. in climate zones 4 and 5, 0.143 µg/N.s; and b. in climate zones 6, 7 and 8, 1.14 µg/N.s. 3. Except for single skin masonry and single skin concrete, where a pliable building membrane is not installed in an external wall, the primary water control layer must be separated from water sensitive materials by a drained cavity.



Recommended Reading

ABCB – Handbook: Condensation Management

[Condensation in Buildings Handbook \(abcb.gov.au\)](https://www.abcb.gov.au/condensation-in-buildings-handbook)

[New condensation requirements in NCC 2019 | NCC \(abcb.gov.au\)](https://www.abcb.gov.au/new-condensation-requirements-in-ncc-2019)

[What is WUFI®? | WUFI](https://www.wufi.com/en/what-is-wufi)

[Waterproofing remediation: How to ensure a successful project](#)



Recommended Viewing

External Recommended Viewing Resources



Air and Vapour Permeability in your buildings wall sarking/wrap details (2019) – YouTube

Durability



12

Chapter 12:

Durability

The durability of the components of a façade is a major factor affecting the whole of life performance of the system including the necessary maintenance regime. Corrosion of metallic elements due to atmospheric conditions or bimetallic corrosion is of particular concern for Project Remediate as some of the cladding systems are metallic and most rely on metal subframing and fasteners.

Determination of Atmospheric Corrosivity

AS 4312:2019 provides guidelines for the classification of atmospheric corrosivity zones in Australia and their effect on corrosion of steel and other metals. The guidelines in this Standard use the corrosion rate classification defined in ISO 9223 to delineate atmospheric corrosivity zones.

Environments which are sheltered from the atmosphere, such as underground and splash zones, are not within the scope of this standard.

Once the corrosivity is determined, the designer is able to select the corrosion protection system and maintenance regime using standards such as AS/NZS 2312.1 for paint coatings or AS/NZ 2312.2 for hot dip galvanized coatings.

ISO 9223 category	Corrosivity	First year corrosion rate of metals, $\mu\text{m}/\text{y}$			Typical environment
		Carbon steel	Zinc	Copper	
C1	Very low	< 1.3	< 0.1	< 0.1	Dry indoors
C2	Low	1.3-25	0.1-0.7	0.1-0.6	Arid/urban inland
C3	Medium	25-50	0.7-2.1	0.6-1.3	Coastal or light industrial
C4	High	50-80	2.1-4.2	1.3-2.8	Sea-shore (calm)
C5	Very high	80-200	4.2-8.4	2.8-5.6	Sea-shore (surf)
CX	Extreme	200-700	8.4-25	5.6-10	Shoreline (severe surf)

Guidance is provided in AS 4312:2019 as to how to determine the Corrosion Category of a site – generally with reference to the distance from a shoreline.

For the Sydney region, the most common environmental conditions to be encountered will be category C3, unless the site is within 1 km of a shoreline with surf or rough sea or 50m from a sheltered bay.

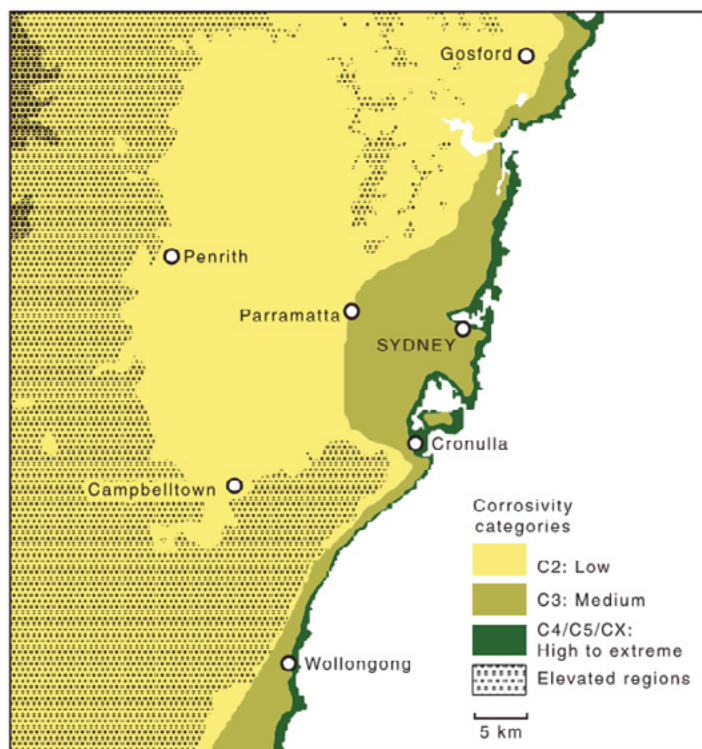

Figure 12.1: AS 4312:2019 estimated ISO corrosivity categories for Sydney (refer to AS 4312:2019 Figure A.4)

Corrosion protection

Elements formed from galvanized sheet

The subframing commonly used such as top hat sections and studs are manufactured from plate which is galvanized prior to forming the structural shape.

The plate and coating is to conform to AS 1397:2021.

The plate is given a designation which relates to the sum of the total mass of coating applied to each side. For example, “Z450” designates a plate with a zinc coating of 225 g/m² on each face. Z275 is commonly used for top hats however Z350 and Z450 plate are available.

The thickness of coating determines the “life to first maintenance”, which may be described as the time at which the corrosion protection system needs replacing or repairing. For subframing supporting a clad façade which cannot be readily accessed, this is effectively the design life of the member.

Given that framing behind cladding cannot be inspected or replaced without causing significant disruption to the occupants, Project Remediate should adopt the minimum specifications for corrosion protection of light-gauge steel elements:

- Zone C2 – Z275
- Zone C3 – Z450
- Zone C4 – do not specify galvanized plate elements.

For cladding panels or subframing, a system comprising a paint system, or a combined galvanized and painted system could be considered provided the system conforms to the specifications provided in AS 2312.1 and achieves a design life of 15 to 25 years (Very Long term “VL”).

Coating designation	Coating mass on one face	Coating thickness one face micrometres	Design Life Climate Zone C2 (years)	Design Life Climate Zone C3 (years)	Design Life Climate Zone C4 (years)
Z275	137	19.2	27 +	9 to 27	4.5 to 9
Z350	175	24.5	34 +	12 to 34	6 to 12
Z450	225	31.5	45 +	15 to 45	8 to 15

Elements formed from hot dipped galvanized sheet

Hot-dip galvanized coatings are to conform to AS/NZS 4680:2006 and are given a designation which defines the coating mass on one surface (e.g., HDG500 has a nominal coating mass of 500 g/m²).

To achieve a design life of 25 years, the minimum specification for hot-dipped galvanized elements would be as follows:

Zone	Maximum Rate of corrosion	Minimum thickness	Minimum coating mass	Minimum coating designation
C2	0.7	36	260	HDG 390
C3	2.1	53	380	HDG 390
C4	4.2	100	714	HDG 700 *

* note that this is non-standard – HDG600 is the normal designation.

Fasteners and Connections

Durability of fasteners and fixings must also be considered, in particular the effects of microclimates and interaction of dissimilar metals.

Stainless steel fasteners are preferred. Designers must also ensure there is a means of separating/isolating dissimilar metals at the associated interface where bimetallic corrosion may occur.



Recommended Reading

NCC-2019 – Section J and NSW Subsection J(A) <https://ncc.abcb.gov.au/editions/2019-a1/ncc-2019-volume-one-amendment-1/section-j-energy-efficiency/section-j-energy>

ICANZ – Insulation Hand Book Part 1: Thermal Performance http://icanz.org.au/wp-content/uploads/2013/04/17132_ICANZ_ThermalPerformance.pdf



Recommended Viewing

External Recommended Viewing Resources

 Hot Dip Galvanizing-Dipping Process. in action – YouTube

Thermal Performance

13

Chapter 13:

Thermal Performance

The thermal performance of a wall is affected by all elements including the external cladding and air gaps such as the cavity between the external cladding and the sarking.

In altering the cladding materials and cavity constructions, the designers need to consider the effect on the overall thermal performance of the wall system as this may interfere with the energy rating of the building and the comfort of occupants.

If a 4mm ACP (R-value = 0.0103m².K/W) is substituted for 3mm solid aluminium (R-value = 0), the overall insulating properties of the wall will be reduced.

The properties of the air cavity are dependent on a number of factors, including:

- Width;
- Emittance of the interior surfaces of the cavity, and;
- Degree of ventilation.

For example, NZS4214:2006 advises that a 40mm fully sealed cavity has an R-value = 0.16 m².K/W whilst a similar cavity which is ventilated has an R-value = 0.07m².K/W.

It is possible that by undertaking a reclad of a building using solid aluminium panels and detailing the cavity to be ventilated, the insulating properties of the wall is reduced by of the order of 0.1 m².K/W.

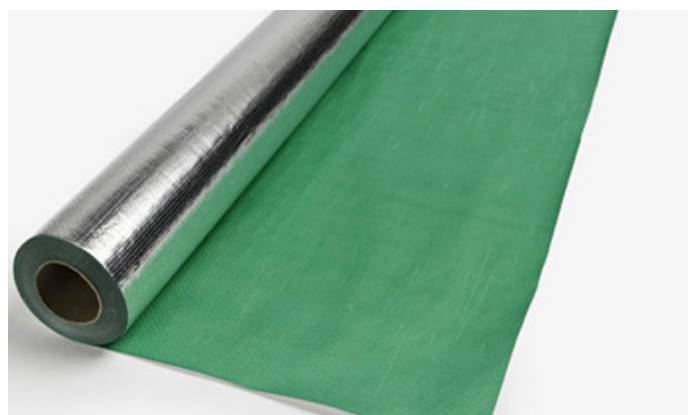

Figure 13.1: Reflective sarking material

Similarly the use of render (R-value = 0.02 m².K/W for 20mm thick cement render) in lieu of ACP cladding over a sealed cavity could result in a reduction of overall wall R-value of 0.15 m².K/W.

Potential mitigation methods which can be considered include:

- Addition of non-combustible insulation within the rainscreen cavity;
- Installation of a reflective sarking which increases the performance of the cavity (for example the use of a reflective surface can increase the R-value of a cavity from 0.07 m².K/W to 0.153 m².K/W which would compensate for the degradation of the performance due to material substitution;
- Increase the width of the cavity (only effective if the original cavity is narrow).

It is stated within CPSP Report 1 that:

“Cladding replacement systems need to be designed fully for each building by appropriate professionals. The Panel notes that it may not be possible to replace cladding systems with a like-for-like solution, however comparable or improved outcomes should be sought where possible for the building.”

This includes thermal performance and energy efficiency.



Recommendations for Project Remediate

Through the triage investigation process, the designers should:

- Review the existing thermal performance wall system and through calculations in accordance with AS/NZS 4859.2:2018 and NZS 4212 : 2006
- Ensure that the proposed solutions do not reduce the wall thermal performance
- Consult with the project BCA consultant and review conditions imposed through the Fire Order with respect to compliance with NCC and BASIX and ascertain if any upgrades to the overall wall performance are required or if energy calculations are required to demonstrate compliance with any regulatory requirements. The BCA consultant will need to advise which version of NCC or rating tool is applicable.

The designers should consider the use of cavity insulation and suitable sarking or wall wrap materials where solid aluminium, solid metal or compressed fibre cement sheets are to be used. Note that any sarking or wall wrap should be vapour permeable.

The designers should consider the reduction in energy performance should non-combustible cement render be considered, and determine whether this is acceptable before this is proposed as a solution.



Recommended Reading

NCC-2019 – Section J and NSW Sub-section J(A) <https://ncc.abc.gov.au/editions/2019-a1/ncc-2019-volume-one-amendment-1/section-j-energy-efficiency/section-j-energy>

NZS 4214:2006 Methods of determining the total thermal resistance of parts of buildings <https://www.standards.govt.nz/shop/nzs-42142006/>

ICANZ – Insulation Hand Book Part 1: Thermal Performance http://icanz.org.au/wp-content/uploads/2013/04/17132_ICANZ_ThermalPerformance.pdf



Recommended Viewing

External Recommended Viewing Resources

 [CSTC WTCB BBRI: Measuring the thermal performance of buildings – YouTube](#)



Wind Loading



14

Chapter 14:

Wind Loading

The design of all cladding elements is influenced by the specific wind conditions applicable to any site and is determined in accordance the Australian Wind Code AS/NZS 1170.2:2021.

Introduction

AS/NZS 1170.2:2021 provides requirements for wind loads in Australia to be used in both structural building wind actions and building façade engineering design pressures. The structural aspects of cladding design are significantly influenced by the associated wind load effects, in addition to serviceability/maintenance loading. The Wind Standard is critical in determining the governing load conditions; however, it is important for designers to understand the limitations of this analytical approach to ensure the cladding and all supporting framing elements are designed to accommodate realistic wind loads.

Designers should be aware that the wind loading standard is, by its nature, reliant upon idealized geometric and site conditions. Although this is compatible with many applications, it is important to understand the potential for unconservative and, therefore, unsafe wind loading considerations, and when it may be prudent to seek specialist advice.

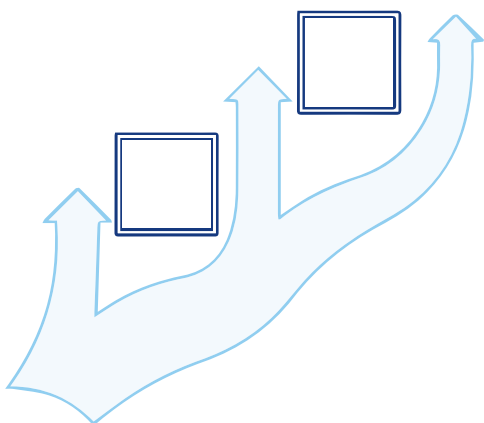

Figure 14.1: Channelling by proximate neighbours can increase cladding pressures

Application of Wind Loading Standard: AS/NZS 1170.2:2021

This Standard's (and its parent Standard AS/NZS 1170.0:2002) approach to estimating ULS peak design pressures has its origins in a great number of wind-tunnel studies on lone rectilinear models. Thus, in most cases it is conservative (as one would desire in such a document), but its direct applicability to a given project may be influenced by attributes such as:

- Non-rectilinear building geometry (e.g., curved buildings)
- Shielding by proximate neighbours. The interaction of the wind flow and adjacent buildings can decrease cladding pressures (refer to Figure 14.2 noting the turbulent, protected flow behind the tall tower)
- Channelling by proximate neighbours can conversely increase cladding pressures by accelerating winds between buildings (Figure 14.1)
- Unusual architectural design features can result in unusually high- or low-pressure areas in the vicinity of these features. Local specific terrain influence versus the generic “hill” and “escarpment” as detailed within the Standard
- Desire for more accurate results via site-specific, building-specific wind-tunnel studies.

Often such a wind-tunnel study results in cost savings through reductions in the areas of high peak pressures, reduced magnitude of those peak pressures, or both.

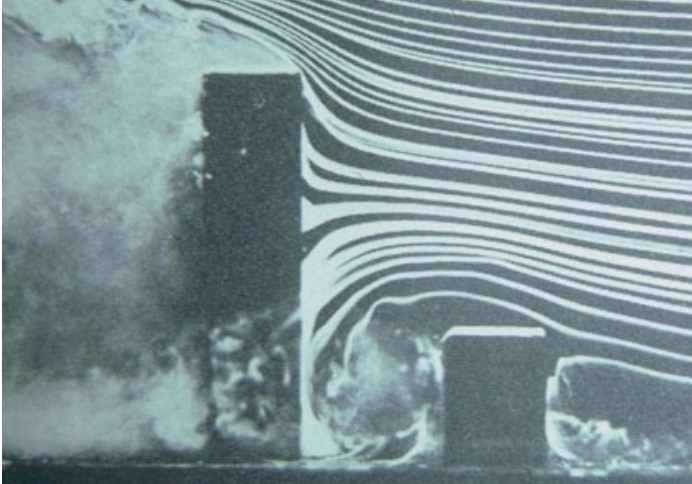

Figure 14.2: Wind Load Effects of Surrounding Buildings -downwash is augmented by upwind shorter building (after Penwarden and Wise, 1975)



Figure 14.3: Wind Tunnel Testing – Turntable of modelled cityscape with upwind spires and roughness behind the photographer



Figure 14.4: Test Model -Wall vortex and separated flow both apparent at the intersection of a tall building and low-rise podium. This vertical vortex has the potential to yield the largest magnitude negative cladding design pressure on a project (after ASCE Webinars 2005-2012)

On the occasions that a wind-tunnel study produces some larger magnitude peak pressures than the Standard would predict, it is critical that the designer is aware and accounts for this in the associated zones accordingly. The flow physics that create large negative pressures is associated with intense vortices at elevated building discontinuities causing a phenomenon referred to as “cross wind response”, and can result in substantially higher ULS peak pressures than the Standard would predict (e.g., -11 kPa observed for a Brisbane building and -16 kPa for a project in Taipei).

AS/NZS 1170.2:2021 is applicable for buildings under 200m in height. For a class 2 building this equates to approximately 60 storeys. In addition, the Standard is only applicable to buildings with natural fundamental vibration periods which are less than 5 seconds (or fundamental vibration frequency which exceed 0.2Hz). This represents buildings which are not deemed to be dynamically sensitive.

The standard provides guidance to ascertain the wind loading on cladding but does not cover some elements such as vertical fins or lightweight elements such as sunshades which can be dynamically sensitive and may resonate at certain wind speeds much lower than design ULS wind speeds.

Wind Tunnel Testing

A standard rectilinear building within a complex cityscape may still benefit from the data generated in a wind-tunnel study due to the substantial influence of nearby buildings.

Once a wind-tunnel study has been properly conducted, the results supersede the Standard results given that these data are a more accurate reflection of the realistic wind loading for a given project. Once a wind-tunnel test has been carried out, those results reflect the minimum loading and designers cannot revert to those pressures found when following the Standard.

There are various factors which often dictate when it is appropriate to consider wind-tunnel testing. One obvious factor is the Standard’s requirement to do so when the building is taller than 200m. Although it may often be assumed as a leading factor, the building height below 200m is not a particularly reliable indicator of the benefits of a wind-tunnel study.

The following variables would instead be considered more representative of cases where such testing may prove beneficial, and should be considered:

1. Complexity and/or “unusual” nature of the architectural design. It should be noted that the term “unusual” -with respect to building geometry -is used in the equivalent North American Wind Standard (ASCE7). Within this Standard, there is no definition offered as to what constitutes such description, despite a considerable effort by the ASCE7 committee to do so. This helps to demonstrate the difficulty in defining set parameters which in turn stipulate the requirement for wind-tunnel testing
2. Curved shapes (2D or 3D surfaces) or unique support systems behind the cladding
3. Ability to assign tributary areas in the model and data reduction process to the support systems to establish cladding design loads (with scope to use influence coefficients)
4. Benefits of shielding within a complex cityscape should not be underestimated
5. Buildings with natural fundamental vibration periods which are greater than 5 seconds or fundamental vibration frequency which are less than 0.2Hz (buildings which are dynamically sensitive).

It is uncommon that façades are designed using both approaches (Wind Standard and wind-tunnel testing), but there are occasions where this has been done. Two such in-house exercises by major consulting firms produced savings ranging from 200 to 400 \$/m² from the wind-tunnel studies. This is not a guaranteed outcome, however, these data act as a useful guide as to the differences which can be found from these differing approaches.

It is also possible to undertake wind-tunnel testing of specific large elements such as sunshades or feature blades to confirm that performance under wind. This testing can also identify if acoustic effects (“whistling”) occur due to perforations.

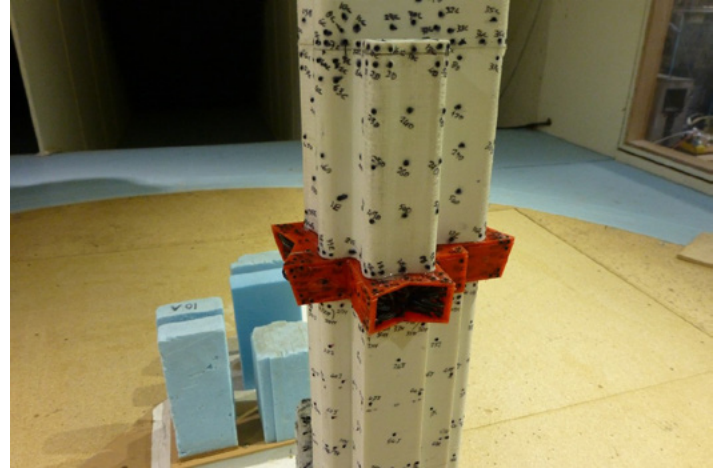
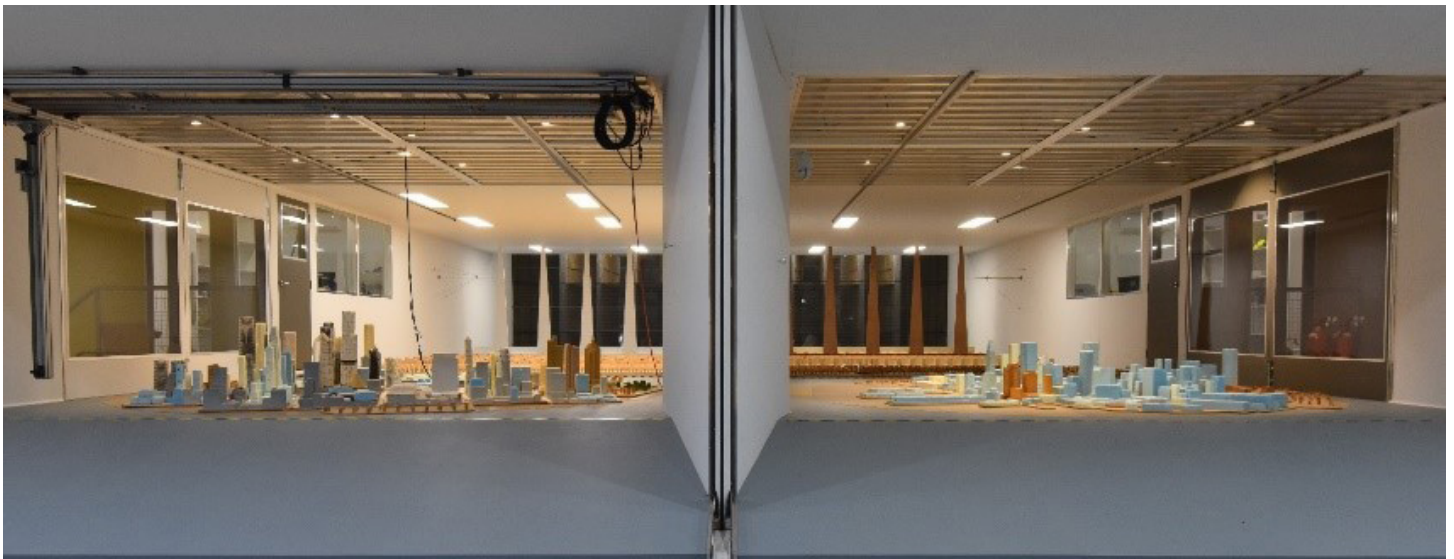

Figure 14.5: Wind Tunnel Testing - Pressure taps at architectural feature locations



Figure 14.6: Wind Tunnel Testing - Pressure taps at varying building geometry



Desk Top Wind Study

Where there is concern over the applicability of AS/NZS 1170.2:2021, it is possible for a Wind Consultant to undertake a desk top review and through previous experience either advise recommended design parameters or confirm if wind tunnel testing is recommended. Such a desktop study, where it experientially varies from AS/NZS 1170.2:2021, cannot be used for final design; only the Australian Standard results or wind-tunnel data may be used for this purpose.

Optimisation of cladding pressures

There are many factors which have an influence on the design pressures including:

- Roughness of surrounding Terrain
- Slope of ground
- Direction of wind
- Shielding provided by proximate buildings
- Height of the cladding panel
- Position of the panel with respect to building corners.

As the wind load is the significant design action for cladding and its supports, to produce an economic design it is recommended to consider all these factors for the 8 wind directions defined in AS/NZS 1170.2:2021. This can be a time-consuming process, however, software exists which automatically assesses these factors for a given location. Results of these programs should always be independently verified.

Wind induced fatigue

The cyclic loading of wind can cause damage to materials which are susceptible to fatigue failure. A particular situation that has been observed is where aluminium panels routed to allow folds at edges to be made. The stress concentration caused by this detail can result in premature failure of the cladding panel. Designers should refer to the relevant material standard and detail accordingly.

Non-typical façade features

Many façade applications involve the use of feature elements which vary from protruding elements or non-standard geometric shapes. The interaction of wind against such elements should be considered when developing the façade design for both existing and new buildings alike.

Vertical, horizontal, or porous area sunshades all have the potential to cause dynamic and acoustic problems.

When not designed for a dynamic response at modest wind speeds, the resulting action may -and has-lead to fatigue failure. This is not uncommon within Australia, with a recent incident in Fortitude Valley, Brisbane involving the dislodgement of two sunshades from a telecom building. No one was injured on this occasion, but fatalities could easily have occurred and may be predicted in our future should such a critical design item fail to be sufficiently addressed.

It is also often the case that the sunshade which fails first is in fact several elements into the field, as opposed to the leading element. Turbulence shed-off upwind sunshades act to buffet those deeper in the field, which can lead to amplified wind actions and responses in zones which are not immediately obvious when considering an idealised geometric building shape alone.

All sunshades have the potential to generate acoustic problems, but the issue is not universal due to a variety of design features such as neighbouring buildings, attachment details, building massing, etc. Consequently, an acoustically active façade/sunshade is not very common, however, when it does occur, it tends to become much publicised within the wider community.



Figure 14.7: Horizontal and Vertical Sunshades

Where a tower sits on a larger podium the designer can expect higher cladding pressures on the tower corner above the podium (up-reaching corner wall vortex) and on the podium corner below the parapet (down-reaching corner wall vortex). Nearby buildings often negate this, but be aware that interruptions in the vertical line of building corners often attracts large negative pressures which may be the largest magnitude on a project (see Figure 14.4).

The topic of internal pressures should be addressed –particularly now that many new tall buildings are residential and not commercial (operable windows and balcony doors now common at height). This influences the remaining fixed façade design as well as the partitions between apartments.

Uplift of loose-laid pavers has been studied in the 1990s and 2000s at Colorado State University, University of Western Ontario and more recently at University of Florida. In general, there is about a 40% pressure equilibration (Sun and Bienkiewicz, 1991) between the top and bottom surfaces of the loose-laid pavers (e.g., small gap between and under pavers) which can aid in using mass to keep in place. However, on many elevated terraces and balconies that is still not sufficient and mechanical or chemical restraint is required. These uplift pressures can easily form part of a wind-tunnel study (see Figure 14.8 below which shows the failed terrace pavers at the Burger King International Headquarters in Miami at Hurricane Andrew) for ULS design pressures.

Another common feature involves the use of ballast gravel on composite roofs. These can become dislodged under wind action, and the ballast should be of a sufficient size and mass to prevent this occurring given the potential danger to nearby buildings' glazing and members of the public and/or residents (see Figure 14.9).



Figure 14.8: Paver uplift damage during Hurricane Andrew in Miami. (after Tom Smith)



Figure 14.9: Gravel dislodgement to elevated roof due to the two horizontal roof-corner vortices generated by the cornering flow approaching the image (after ASCE Webinars 2005-2012)

The removal of sharp edges from punched or laser-cut sunshades can reduce the tendency to acoustic problems. Rounding penetration surfaces with paint systems can be valuable.

The fundamental natural frequency of sunshade systems does not represent a “good guide” to fatigue problems as some may believe. Designers should be aware that relatively stiff components can still generate cycling problems. Designers should not confuse the frequency limits defined within AS/NZS 1170.2:2021 as applying to components. The 1Hz limit for dynamic issues in the Standard applies to buildings as a whole, not part of a building. This is discussed within a paper by Wood, Bourke and Banks, 2016.

There is also currently a lack of detail within the Standard with respect to determining wind loads on protruding façade elements such as sunshades. In addition, the small size of these feature façade items relative to the overall buildings are such that there is great difficulty in collecting accurate data from wind-tunnel tests. There are various methods and approaches towards quantifying the wind loads on such items and the notes below seek to provide some guidance as to what may be considered:

- During a wind-tunnel cladding pressure study, pressure taps on the façade either side of the modelled sunshades may be used to obtain the differential peak pressures across the fin or sunshade element as an aid to design the shades themselves
- If the sunshade fin is relatively small one may place a hot-wire anemometer within close proximity to the façade on the wind-tunnel model at the location where the sunshade would be (fin not on the model itself) and use the peak velocity, combined with a sunshade mean drag coefficient, to estimate peak loads. This process works best if the sunshade element or fin is a simple rectilinear shape where drag coefficient data are known
- Depending on design geometry, a larger than typical wind-tunnel model (or partial model) of the building can be used in the boundary-layer wind tunnel to obtain differential pressures across sunshade elements.

The top two methods of approximating the associated wind loads are open to Reynolds Number criticism so some skill and judgement (e.g., larger model scale to allow for a more useful fin size) is required by the wind-engineering laboratory. Even some minor scale distortion of the fins themselves may be considered.

Tall, thin-walled aluminium sections of varying profiles (e.g., rectilinear, circular, elliptical hollow sections, etc.) and of relatively lightweight construction have been utilised as balcony-edge sunshade devices at beachside locations within coastal regions across Australia. These may be fixed or moveable and often be upwards of 3m in height, which results in slender elements and susceptibility to dynamic action. The end-product is often found to be dynamically active and, perhaps, noisy and designers should avoid such applications.

References:

Penwarden, A.D. and Wise, A.F.E., "Wind Environment Around Buildings", Building Research Establishment Report, Number 9(E7), Her Majesty's Stationery Office, 1975.

Wood, G.S., Bourke, P.A. and Banks, D., "Dynamic Response of Structures with Frequencies Greater than 1 Hz", 18th Australasian Wind Engineering Society Workshop, McLaren Vale, 2016.

Sun, Y. and Bienkiewicz, B., "Wind-Tunnel Study of Wind Loading on Loose Laid Roofing Systems", Proceedings of the Eighth International Conference on Wind Engineering, University of Western Ontario, London, Canada, June, 1991.

Bienkiewicz, B. and Sun, Y., "Local Wind Loading on the Roof of a Low-Rise Building", Journal of Wind Engineering and Industrial Aerodynamics, Volume 45, pages 11-24, 1992.

Sun, Y. and Bienkiewicz, B., "Wind-Tunnel Study of Wind Loading on Loose Laid Roofing Systems", Proceedings of the Eighth International Conference on Wind Engineering, University of Western Ontario, London, Canada, June, 1991.

Standards Australia, Standards New Zealand, "Australian/ New Zealand Standard, Structural design actions, Part 2: Wind actions", AS/NZS 1170.2:2021, 2021.



Recommendations for Project Remediate

- Wind loads are to be calculated in accordance with AS/NZS 1170.2:2021 Structural design actions – Part 2: Wind actions
- Effects of topography, surrounding terrain, wind directionality and shielding from adjacent buildings are to be considered in detail
- Designers are encouraged to confirm results using verified software to optimise the design loads and produce the most economic design
- Where situations are encountered which are not clearly covered by AS/NZS 1170.2:2021, a Wind Consultant should be engaged to undertake a desk top study and/or a wind-tunnel study
- All cladding, subframing such as top hats and fixings to the structural wall should be designed for the local pressures specified by AS/NZS 1170.2:2021
- If open (unsealed) joints are used and have not proven to be perform satisfactorily in a similar situation, then acoustic performance should be considered
- Routing at bends in aluminium should be avoided unless additional reinforcement of the corner is provided.



Recommended Reading

Journal of Wind Engineering and Industrial Aerodynamics (Elsevier) https://www.sciencedirect.com/journal/journal-of-wind-engineering-and-industrial-aerodynamics?_gl=1*bwfpqd*_ga*MTkzMzQwNDYzMi4xNjUzODg3OTAy*_ga_4R527DM8F7*MTY1Mzg4NzkwMi4xLjEuMTY1Mzg4NzkwOC4w

Building and Environment (Elsevier) <https://www.sciencedirect.com/journal/building-and-environment>

Wind and Structures <http://www.techno-press.org/?journal=was&subpage=5>

Wind Loading of Structures (J.D. Holmes) <https://www.routledge.com/Wind-Loading-of-Structures/Holmes-Bekele/p/book/9780367620691>

Review(s) of: Wind loading handbook for Australia and New Zealand: Background to AS/NZS 1170.2 wind actions, by JD Holmes, KCS Kwok and JD Ginger, ISBN: 0975037617, 9780975037614, Australasian Wind Engineering Society, 2012, 122 pp. Note that the new 2021 pdf version of this is due to be issued by AWES next month

Wind Effects on Structures: Modern Structural Design for Wind <https://www.wiley.com/en-au/Wind+Effects+on+Structures:+Modern+Structural+Design+for+Wind,+4th+Edition-p-9781119375883>

Wind Loads on Structures (Dyrbye & Hansen) <https://www.wiley.com/en-us/Wind+Loads+on+Structures-p-9780471956518>

Proceedings of the International Conference on Wind Engineering

Australasian Wind Engineering Society www.awes.org

Wind Loading Handbook for Australia and New Zealand: Background to AS/NZS 1170.2 Wind Actions <https://www.awes.org/product/wind-loading-handbook-for-australia-new-zealand-background-to-asnzs-1170-2-wind-actions/>



Recommended Viewing

External Recommended Viewing Resources

 [Play video](#) How Tall Buildings Tame the Wind

 [Play video](#) Flow Visualisation Around Simple Building Shapes in Wind Tunnel

 [Play video](#) Wind Engineering public lectures on Australasian Wind Engineering Society

 [Play video](#) Wind Engineering Lectures

Triage Investigations



15

Chapter 15:

Triage Investigations

Preliminary investigations with limited testing have been undertaken to identify combustible cladding on buildings. Project Remediate has developed a methodology to undertake detailed “Triage” Inspections to clearly identify the scope of the work, confirm which cladding needs replacement and to identify situations which need to be rectified to ensure adequate performance of the new cladding.

The triage process

For each building, a specialist façade consultant and contractor are engaged to undertake a comprehensive investigation of the existing façades involving opening up works and testing where appropriate. Guidelines and standard reporting templates have been produced to help define the scope of works and processes to ensure the necessary information is gathered with minimal disruption to the building occupants.

Typical information that is to be gathered includes:

- Existing fixing details for cladding
- Nature and condition of subframing
- Nature and condition of structural system supporting subframing
- Existing weatherproofing system
- Wall build up including insulation
- Presence of combustible components such as combustible insulation
- Details at interfaces with adjoining elements such as windows and door frames
- Any existing situations which should be rectified prior to installation of new cladding.

The information is to be provided to the design teams and is intended to minimise the risk of encountering latent problems and ensure longevity of the remediated façade.

Results of the triage process

The triage investigations undertaken for the initial tranche of buildings have provided considerable insight into the typical standards of construction. A significant number of situations were identified that would have resulted in considerable variations to the recladding contract.

As a result of inherent situations in all buildings inspected a straightforward “like-for-like” reclad is not possible.

Typical common situations which have been identified from the triage inspections which had been carried out at the time of writing. These common situations are listed to follow.

Type 1 – Lack of mechanical fasteners for cladding

The majority of cladding inspected has been fixed to the supporting top hats with either double-sided tape or silicone sealant.



Figure 15.1: Cladding fixed to the supporting top hats with silicone sealant



Figure 15.2: Cladding fixed to the supporting top hats with double-sided tape

Type 2 – Corroded subframing

Standard galvanized coatings commonly supplied are insufficient to achieve a significant design life for buildings within close proximity to the coastline.



Figure 15.3: Standard galvanized coatings showing significant deterioration (located within close proximity to the coastline)



Type 3 – Inadequate Fixings of subframing to supporting structure



Figure 15.4: Inadequate fixings of subframing to supporting structure



Type 4 – Inadequate waterproofing including inadequate flashing and poor detailing resulting in moisture ingress



Figure 15.5: Inadequate weatherproofing resulting in moisture ingress



Type 5 – Inadequate wall structure



Figure 15.6: Inadequate wall structure



Type 6 – Inadequate fire protection/detailing

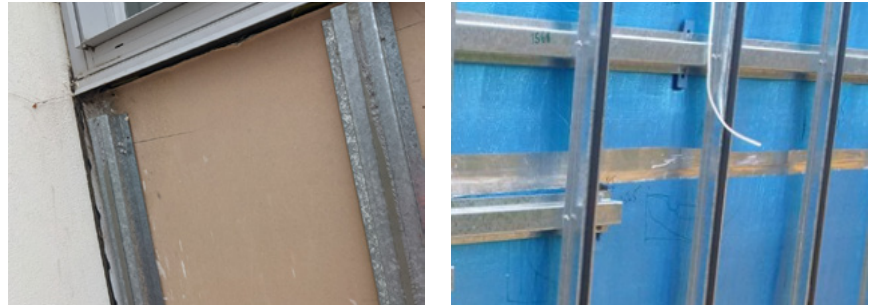

Figure 15.7: Inadequate fire protection and detailing

Type 7 - Combustible components



Figure 15.8: Combustible components (packers)

Type 8 – Inadequate or lack of insulation



Figure 15.9: Inadequate or lack of insulation

Situation type	Description	% of buildings situation observed *
1	Lack of mechanical fasteners for cladding	64
2	Corroded subframing	71
3	Inadequate fixings of subframing to supporting structure	42
4	Inadequate waterproofing	64
5	Inadequate wall structure	42
6	Inadequate fire protection/detailing	57
7	Combustible components	64
8	Inadequate insulation or lack of	7

* Record values shown represent the total % of buildings at the time of writing

NCC 2022 Cl. C2D10 (4) provides an exemption to the combustibility requirements attributed to construction shims when used in isolation. Project Remediate, however, maintains the position that non-combustible materials shall be prohibited for use in new works adhering to the program requirements. Consequently, plastic packers remain prohibited for use in Project Remediate.

Schedule of Situations

The following schedule sets out the typical situations encountered during the Triage investigation process. For each situation, the root causes and processes leading to such situation(s) are identified.

Defect type	Situation	Description	Root cause	Deficient code requirements	No design undertaken or specification provided	Incorrect design specification	Inadequate supervision of the construction work	Construction errors
1	Lack of mechanical fasteners for cladding	<ul style="list-style-type: none"> • Panels directly fixed to sub-framing or support structure with silicone, adhesives or double-sided tape 	<ul style="list-style-type: none"> • No design specification by façade engineer • Incorrect recommendations from cladding suppliers • Construction not inspected by building certifier of delegated consultant 	✓	✓	✓	✓	
2	Corroded sub-framing	<ul style="list-style-type: none"> • General corrosion of mild steel framing supporting cladding panels • Corrosion of exposed cut or drilled edges of light-gauge galvanized steel elements • Corrosion of fixings and fasteners 	<ul style="list-style-type: none"> • Incorrect material specification • No design specification by façade engineer • Use of inappropriate generic supplier recommendations • Construction not inspected by building certifier of delegated consultant 		✓	✓	✓	
3	Inadequate fixings of sub-framing to supporting structure	<ul style="list-style-type: none"> • Use of shot-fixed nails • Inadequate number of fixings to cater for applied wind loads 	<ul style="list-style-type: none"> • No design specification by façade engineer • Construction not inspected by building certifier of delegated consultant 		✓		✓	
4	Inadequate weatherproofing	<ul style="list-style-type: none"> • Reliance on cladding as primary waterproofing barrier • Lack of sarking • Poor detailing of flashings around doors and windows • Poor detailing of parapet capping • Poor detailing of interface with roof and slab membranes 	<ul style="list-style-type: none"> • Poor or lack of appropriate waterproofing detailing (design); or • Construction not carried out in accordance with design; or • Degradation of materials resulting in loss of integrity of overall waterproofing system 		✓	✓	✓	✓
5	Inadequate wall structure	<ul style="list-style-type: none"> • Undersized wall studs and/or fixings • Damaged wall studs (cut to accommodate services) • Inadequate tying of masonry walls to structure 	<ul style="list-style-type: none"> • Poor or lack of appropriate structural design of substrate • Construction not carried out in accordance with design 		✓	✓	✓	✓
6	Inadequate fire protection/detailing	<ul style="list-style-type: none"> • No spandrel protection installed • Spandrel protection only one way (requires performance solution) • Inadequate sealing of fire board to adjacent structures • Inadequate fire stopping 	<ul style="list-style-type: none"> • Poor or lack of appropriate fire protection detailing (design) • Construction not carried out in accordance with design 		✓		✓	✓
7	Combustible components	<ul style="list-style-type: none"> • Plastic packers • Non-compliant sarking • Non-compliant insulation 	<ul style="list-style-type: none"> • Design not provided • Unapproved construction materials used 		✓		✓	✓
8	Inadequate insulation	<ul style="list-style-type: none"> • No insulation installed • Poorly installed insulation which does not fill wall cavities sufficiently • Cold bridging resulting in condensation within wall cavity 	<ul style="list-style-type: none"> • Construction not carried out in accordance with design • Previous versions of NCC did not specifically address thermal bridging 	✓			✓	✓

Other situations

During the triage processes other situations not related to the façade have been identified. Typical situations include

- Inadequate or failed waterproofing
- Inadequate balustrade fixings
- Corrosion of embedded reinforcement in concrete due to lack of cover.

These situations are to be identified to the owners corporation and a strategy developed to integrate the rectification of these elements with the recladding works.

Presentation to the Owners Corporation

The design consultants are to present the results of the triage investigations to the owners corporation.

From the inspections undertaken in the first tranches, it is likely that rectification works will be required in addition to replacement of non-compliant cladding. The costs should be clearly identified and explained. It is likely that previous quotations have been sought which do not allow for the full scope required to ensure longevity and safety of the façade. Analysis of previous designs and quotations should be made prior to any presentations so that the 30% cost estimates can be aligned with any preconceived expectations.

Rainscreen Façades



16

Chapter 16:

Rainscreen Façades

A common form of construction which will be employed in recladding solutions is the rainscreen. This can be formed using a wide range of cladding materials and can be detailed to enhance the thermal performance of an existing façade and improve weatherproofing.

Rain Screen Façades

A rainscreen façade is a two-level construction system – an inner insulated wall, protected by an outer skin. This skin provides a shield against rain and moisture. An air space is maintained between the cladding and the building wall which prevents water from infiltrating the building's structure. It is one of the most effective approaches to moisture control utilised currently.

How a rain screen works

The key features of a rainscreen façade are:

1. An outer cladding;
2. Cavity;
3. Wall membrane – which can serve as an air and vapour barrier;
4. Insulated airtight backing wall.

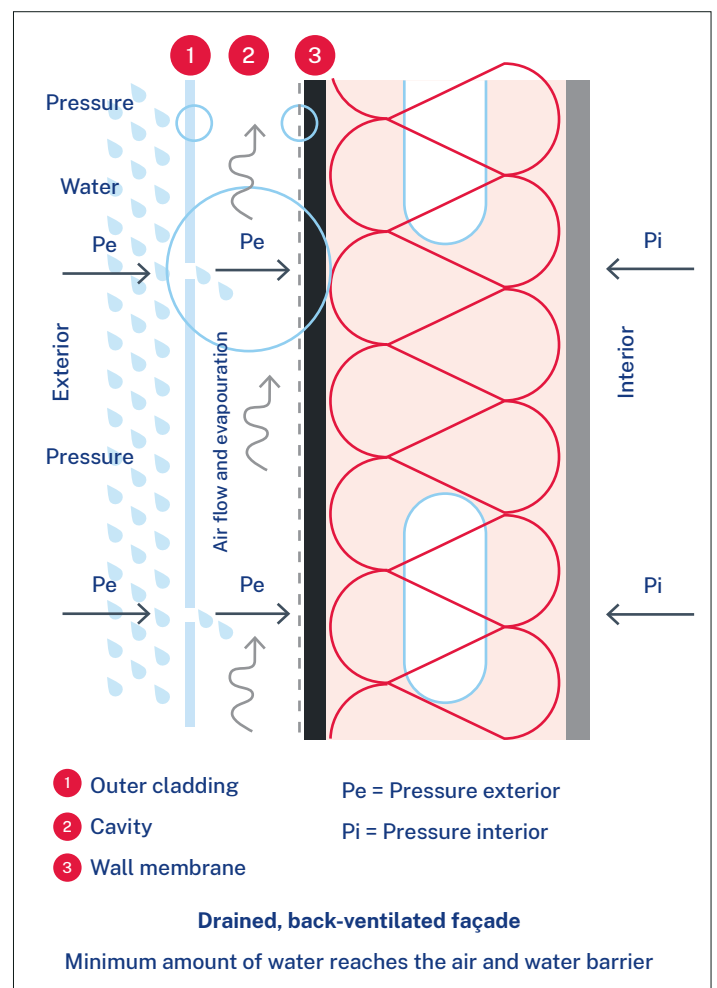

Figure 16.1: The key features of a rain screen

Outer cladding

This is a durable, non-porous material, designed to shed most if not all water, and bears the primary brunt of exterior weather forces.

Cavity

The cavity is essential to the effectiveness of the rainscreen system. Providing a secondary line of defence against the elements, it serves two purposes:

1. Allows drainage of any moisture that may penetrate the outer cladding;
2. Allows air circulation, evaporating moisture from the surface of the air-and-water barrier and drying the cavity.

A minimum cavity depth of 25mm should be maintained to allow sufficient air movement. As a general rule of thumb, walls greater than 25m high should have a cavity depth of 1mm per meter in height. For example, a 50m wall with a continuous cavity should have a minimum depth of 50mm. The cavity may be broken and drained at individual floor levels.

Wall Membrane

This is the final layer of protection, preventing any moisture from penetrating the building walls. It may be vapour permeable or non-permeable depending on the requirements for condensation management. All penetrations should be sealed.

“Wet Zone”

This comprises the components of the wall which are exposed to external moisture. This will include all elements exterior to the wall membrane including cladding and subframing supporting the cladding.

“Dry Zone”

This comprises all elements inside the building membrane and not subject to external moisture. This includes the structural framing and insulation. Note that some moisture may be present in this zone due to condensation at times.

Drainage plane

The drainage plane in a rainscreen comprises the air gap and the water resistant membrane fixed to the outside of the backing wall structure. The design must ensure there is an unobstructed drainage path for liquid moisture to drain from a high point of the wall (where it enters) to a low point of the wall (where it exits). The drainage plane

must move the water out of the wall system quickly to prevent absorption and consequential mould, and structural degradation. The designers must ensure that weep holes are provided that allow the cavity to drain without causing damage to other elements of the wall.

Rainscreen designs

As classified by the American Architectural Manufacturers Association, there are two basic types of rainscreen systems:

1. Drained, Back-Ventilated (AAMA 509-09)
2. Pressure Equalised (AAMA 508-07).

Also in common usage is a third type:

3. Vented Rainscreen.

Drained, back-ventilated

Drained and back-ventilated have a continuous airspace, with openings at top and bottom of a wall section to encourage air movement. These systems can stop well over 90% of the water that could potentially reach the air and vapour barrier of the building. The remaining small quantity of water is then dissipated through the combined action of gravity (drainage) and air circulation (evaporation).



Figure 16.2: Ventilated façade principles (airflow)

Pressure equalised

Pressure equalised rainscreens are gaining prevalence in Europe as the optimum waterproofing solution. The system relies on a cavity pressure that matches the external air pressures. This is achieved through open joints and compartmentalising the cavity. The benefit of this system is that as air pressures are equal there is no air movement to force rainwater into the cavity. As the cavity pressures match external wind pressures however, the air and vapour barrier must be able to absorb the wind loads. As such this system is mainly suitable for masonry construction or where a rigid air barrier is installed.

Vented rainscreen

Vented systems are only open at the bottom, with the primary focus being to drain moisture. These are mainly used with face-sealed cladding systems, aiming to deal with condensation and potential long-term system failure (e.g., sealant deterioration).

Benefits of rainscreen façades

The benefits of rainscreen façades are:

- Superior weatherproofing – rainscreen façades protect the structure of the building from moisture, including rain and condensation, through a multi-layer barrier system, and is less dependent on sealants and site workmanship for weatherproofing performance.
- Long-term durability – rainscreen façades are sealant free, and hence are less subject to deterioration over time, and the maintenance cost of dealing with this.
- Thermal efficiency – the rainscreen cladding helps shade the structure and dissipate heat. Rather than letting heat transfer into the structure (particularly the heat absorbed from direct sunlight), this is radiated into the cavity. The warm air moves up and out the cavity by convection, drawing in cooler air at the base and insulating the primary wall structure.

Application to Project Remediate

Cladding Selection

For Project Remediate, the permissible cladding types are specified by the Cladding Product Safety Committee.

Currently these include:

- Solid Aluminium
- Solid Metal Sheets
- Fibre cement
- Non-combustible Cement Render
- Engineered Ceramic Cladding Systems (ECCS)
- Bonded Laminated Materials (BLM).

Generally, it is expected that a “like-for-like” substitution should be made with respect to:

- Colour
- Texture
- Reflectivity.

Cladding design and selection

Apart from cement render, all other types should be constructed as rainscreens. As open joints would alter the appearance of the façade, joints will be sealed with ventilation and drainage holes provided. As such, the wall should be assumed to be vented but not pressure equalised. Cladding and subframing should be designed to resist the full anticipated wind pressures.

Cladding Type	Advantages	Disadvantages	Comment
Solid Aluminium	<ul style="list-style-type: none"> • Readily replaces existing ACP • Good corrosion resistance 	<ul style="list-style-type: none"> • Thermal performance less than ACP 	
Solid Metal Sheets	<ul style="list-style-type: none"> • Light weight 	<ul style="list-style-type: none"> • Available profiles generally not a substitute for ACP flat panels 	
Compressed Fibre Cement	<ul style="list-style-type: none"> • Alternate material if aluminium is difficult to source • Robust for accessible areas 	<ul style="list-style-type: none"> • Add weight to a building • Colour and texture may not be a suitable substitute • Often requires exposed screw fixings • Limited ability to form curved profiles 	Structural elements need to be checked for additional loads
Non-combustible Cement Render	<ul style="list-style-type: none"> • Occupies the least space if constructing on a boundary or adjacent to a setback • Cost effective 	<ul style="list-style-type: none"> • Colour and texture not a substitute for ACP • Does not provide weather protection to backing wall • Requires a sound masonry backing wall 	Designer to confirm waterproofing system does not rely on the cladding. Use of this may require additional planning approvals
Engineered Ceramic Cladding Systems (ECCS)	<ul style="list-style-type: none"> • High quality finish architecturally 	<ul style="list-style-type: none"> • Add weight to a building • Colour and texture may not be a suitable substitute 	Use of this may require additional planning approvals
Bonded Laminated Materials (BLM)	<ul style="list-style-type: none"> • Readily replaces existing ACP • Good corrosion resistance • Good thermal performance 	<ul style="list-style-type: none"> • Fire performance needs to be proven through fire tests in accordance with CPSP requirements 	

Cladding Support

The cladding panels are to be mechanically fastened to a subframe which in turn is connected to the main wall backing structure. The subframe is considered to be in an external “wet” environment. The materials used should have suitable corrosion resistance for this situation. Care should be taken to ensure that the thickness of galvanized coatings is sufficient. The subframing is to allow the wall drainage plane to be fully effective.

Wall Membranes

It is possible that the original wall cladding (intentionally or otherwise) provides the primary waterproofing barrier and that a membrane was never incorporated into the wall system. The designers should examine the existing wall build-up and identify where the interface between the “wet” zone and “dry” zone occurs. If this is not clear then consideration should be made to install a vapour permeable barrier behind the cladding support.

Backing Wall Structure

The supporting wall structure is located inboard of the wall membrane. Elements within this wall such as structural framing and insulation are protected from external moisture. Note however that condensation can potentially occur in this space depending on the type of wall membrane and the range of temperature and humidity – the designer must assess the risk of this occurring and provide a method to drain this space if this can occur.

The Pattern Book anticipates two types of backing wall are to be encountered:

- Steel framed – the load resisting elements will consist of discrete elements such as light gauge steel studs or steel girts. The subframing supporting the cladding will be required to span between these elements. Wall membranes are unsupported between structural supports. In situations where high wind pressures are encountered, pliable membranes may not be suitable and a rigid air barrier (RAB) may be required.
- Solid construction (masonry and concrete) – the wall structure is able to provide continuous support to the subframing which effectively becomes a packer between the cladding and the wall structure. This wall typology includes concrete block, clay brick, in situ and precast concrete and aerated autoclaved concrete (AAC). Appropriate fixings for each need to be selected. The Pattern Book provides suggested methods for each wall type. Designers will need to consider how the backing wall structure responds to condensation and ensure that existing weep holes are maintained and allowed to drain without causing damage to the building fabric.

The decision as to whether to install a membrane is to be made by the designer. In addition to a condensation risk assessment, the integrity of the wall to prevent the ingress of water should be reviewed. Factors such as quality of mortar filled joints, cracks and other situations should be considered.

Cladding R-value

By replacing the existing cladding materials with a suitable alternative, the respective thermal resistance rating (R-value) will be modified accordingly. It will be necessary for the proposed cladding materials to achieve an R-value which achieves or improves upon that of the existing R-value, and the designer should determine this as having been achieved through thermal modelling or similar methods.

Use of Packers

It is inevitable that there will be a degree of variability in the alignment of the outer face of the backing wall. It will be necessary to provide tolerance in the connection of the cladding subframing to the backing wall. Commonly packers are utilised to provide the necessary adjustment at the fixing points. Options have been provided in the Pattern Book which include the use of packers. The program requires that material used for these packers must be non-combustible as defined by AS 1530.1.

Building Movements

The façade must be articulated to accommodate movement of the structure. These movements can include:

- Vertical deflections of the edges of the floor structure
- Differential vertical settlement of columns and walls
- Vertical movement of slabs on ground due to expansion of reactive soils
- Lateral interstorey drift due to wind and seismic events
- Thermal expansion/contraction of the floor and wall structures
- Shrinkage and creep of the concrete structure
- Growth or shrinkage of masonry walls.

As a guide, the designers should identify all existing movement joints in the structure and backing wall and ensure that the cladding and sub framing allows these joints to move as required. The new façade should be jointed to avoid bridging or tying together building elements.

Technical Paper: Routed Aluminium Corners

Discussion

The manufacturing technique involving the routing of cladding materials was originally implemented as part of the fabrication techniques for bonded laminate panels. This technique allows a corner to be bent without requiring undesirably large bending radii. It involves cutting a groove along the proposed fold line. This groove cuts through the inner aluminium sheet and reduces the thickness of the inner core material with the outer sheet remaining intact. The panel can then be more readily bent along the fold line.

Where solid aluminium sheet is to be used to form similar cassettes, the best practice from a viewpoint of structural integrity is to fold the solid sheet to a radius which suits the specific type of aluminium. This is the detailed proposed in the Pattern Book.

From a structural performance perspective, the routing process significantly weakens the solid sheet and increases susceptibility to fracture under cyclic loading. It is understood that a number of manufacturers within the cladding industry subscribe to the use of this manufacturing technique and associated detail.

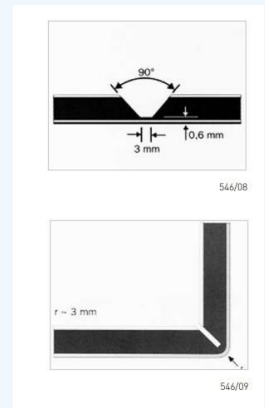
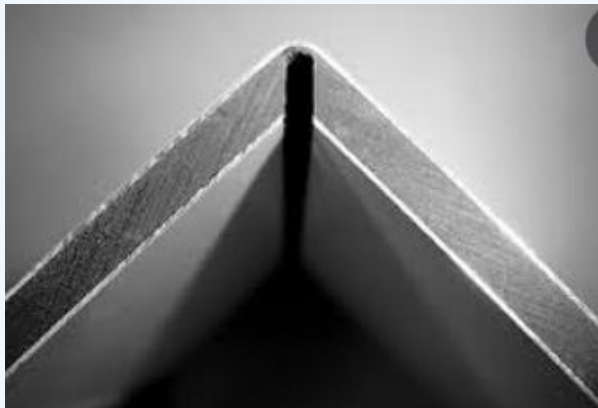

Figure 16.3: Folding of aluminium composite panels

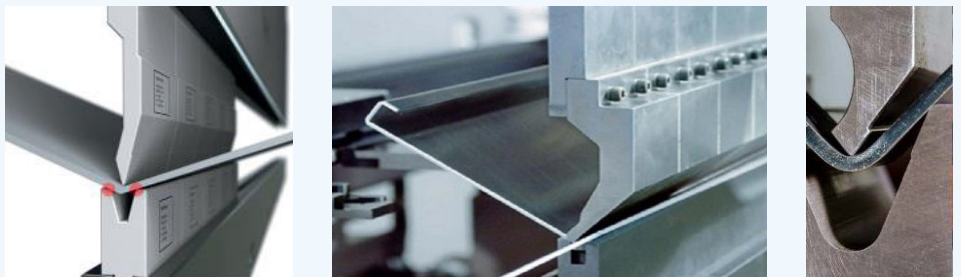

Figure 16.4: Folding of aluminium sheet using mechanical methods including break pressing

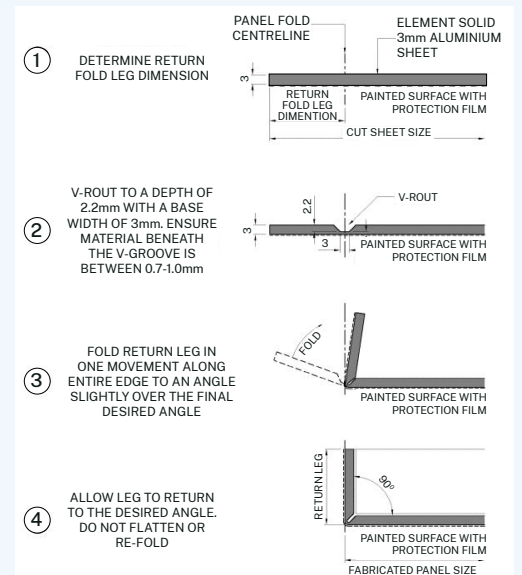
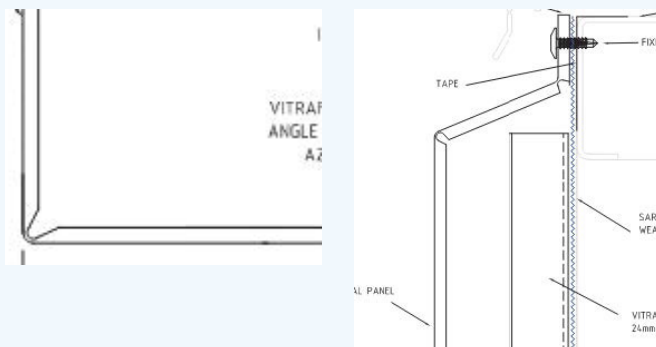

Figure 16.5: Folding of aluminium sheet using routing techniques



To address the risks associated with such a manufacturing technique, methods have been developed to mitigate the associated material weakness involving the strengthening of the fold via the installation of an internal edge stiffeners with the specific detail varying between suppliers. For example the folded corner can be reinforced with a “Z” or “L” shaped extrusions.

The façades generally acts as a critical component of a building’s design and consequently there are often feature façade elements incorporated to enhance its appearance. These feature façade elements can often be observed as comprising protruding elements which may be framed using complex extrusions or built-up framing systems.

The principal followed for all these configurations is that the panels are bonded to the stiffeners to achieve structural integrity. The fold is rivetted or screwed only to provide mechanical connections for safety and performance under fire conditions. The products utilised are classed as sealants by the manufacturers and therefore have been found to benefit from the exemption of such elements as outlined within Clause C1.9(d) under NCC 2019 (+A1).

These systems can be engineered and verified by testing.

The European Organisation for Technical Assessment (EOTA) has developed a methodology for testing the performance of composite panels which includes fatigue testing. This is outlined in their publication “Assessment procedure for durability of thin metallic composite panels TR-038 August 2012 Amended June 2017”. This provides a useful testing framework which could be adopted to demonstrate performance of a system.

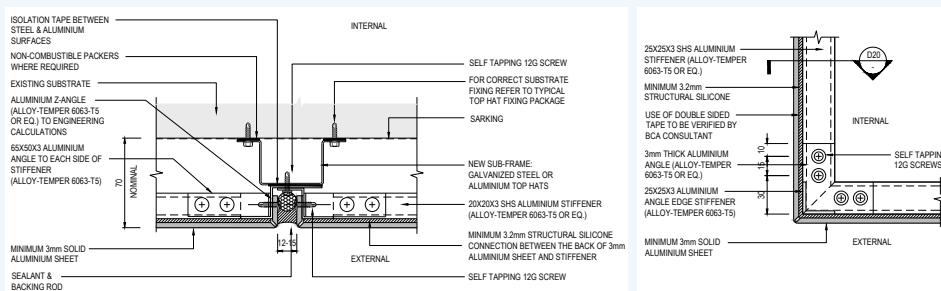

Figure 16.6: Example: V-groove return strengthening method (Pattern Book)

C1.9 Non-combustible building elements

- (a) In a building *required* to be of Type A or B construction, the following building elements and their components must be *non-combustible*:
- (i) *External walls* and *common walls*, including all components incorporated in them including the facade covering, framing and insulation.
 - (ii) The flooring and floor framing of lift pits.
 - (iii) *Non-loadbearing internal walls* where they are *required* to be *fire-resisting*.
- (b) A *shaft*, being a lift, ventilating, pipe, garbage, or similar *shaft* that is not for the discharge of hot products of combustion, that is *non-loadbearing*, must be of *non-combustible* construction in—
- (i) a building *required* to be of Type A construction; and
 - (ii) a building *required* to be of Type B construction, subject to C2.10, in—
 - (A) a Class 2, 3 or 9 building; and
 - (B) a Class 5, 6, 7 or 8 building if the *shaft* connects more than 2 *storeys*.
- (c) A *loadbearing internal wall* and a *loadbearing fire wall*, including those that are part of a *loadbearing shaft*, must comply with Specification C1.1.
- (d) The requirements of (a) and (b) do not apply to the following:
- (i) Gaskets.
 - (ii) Caulking.
 - (iii) Sealants.
 - (iv) Termite management systems.
 - (v) Glass, including laminated glass.
 - (vi) Thermal breaks associated with glazing systems.
 - (vii) Damp-proof courses.
- (e) The following materials may be used wherever a *non-combustible material* is *required*:
- (i) Plasterboard.
 - (ii) Perforated gypsum lath with a normal paper finish.
 - (iii) Fibrous-plaster sheet.

Figure 16.7: Extract from NCC 2019 (+A1)



Figure 16.8: Fatigue testing of solid aluminium panels

Conclusion

The concerns raised within the preceding section are valid for the situation where aluminium is folded using routing in the absence of additional strengthening measures.

A detail reflecting an unstiffened folded edge does not form part of the Pattern Book nor would this approach be supported by the GFC.

There are design details which may be implemented and functioning in strengthening sheets which have been routed and subsequently folded. These details include the following:

- strengthening the corners where a fold occurs, and;
- transferring the associated loading to the supports via stiffeners fixed to the rear of the aluminium cladding.

The overarching principle being that a routed corner is not to be relied upon to transfer load under service conditions.

These solutions are to be engineered for each specific situation with all factors considered such as the flexing of corners due to thermal expansion.

The fabrication must be subject to quality controls to ensure that the sheets are not over cut and that any sealants/adhesives are both effective as well as compliant with the NCC.

For Project Remediate, mechanical fasteners will continue to be mandated to ensure that cladding panels remain anchored to the structure in the event of fire or the failure of any structural sealants.

Where a contractor proposes unstiffened routing as an alternative, proof through testing or substantive engineering analysis would be required to demonstrate suitability.

Technical Paper: Sealants

Introduction

The following technical paper discusses common industry practice with respect to properties, compliance to Standards and recommended testing of sealants and joints that will be widely used in the projects moving forward.

Both structural silicone and non-structural sealants are relied upon within the cladding industry. Structural silicone is often used where attaching differing structural components, such as stiffeners fixed to the rear of cladding panels. Sealants are used in non-structural applications and will typically function in providing a seal between components to prevent water ingress. Depending upon the function and application, differing materials are used. The purpose of this paper is to provide clarity around the material performance differences and considerations which may be used to inform those specifying the associated products.

This paper will discuss these topics and aspects and will provide some guidance on acceptance and good industry practice that should be followed.

Bonding Systems

Structural adhesive bonding is a widely used joining method which can result in high-performance joints when aluminium is joined to aluminium which also includes other materials.

Adhesion forces are the attraction forces occurring in the interface between two surfaces in contact with each other. The attraction force between an adhesive's molecules and the surface to be bonded is effective over a maximum distance of 0.5 nm (1 nm = one millionth of a millimetre) for chemical adhesion to occur. The term surface tension is used for liquids and gases while

the same thing for solid materials is referred to as surface energy; the units used are the same.

It can happen that a newly installed sealant joint abuts on an existing one and therefore different sealants get in contact with each other. In that case it is crucial to check the sealant's compatibility. Chemical incompatibility and/or plasticizer migration can lead to adhesion problems and may influence the cohesion. The following table advises which sealant technology may contact another one. Nevertheless, adhesion and compatibility tests are recommended in each individual case.

Table 1: Joint sealant compatibility matrix
 ++ Preferable replacement solution
 + Good replacement solution
 - Non-feasible replacement solution

Replacement sealant \ Sealant to be replaced	Polyurethane	Silane terminated polymer	Silicone
Polyurethane	++	+	+
Silane terminated polymer	+	++	+
Silicone	-	-	++

Figure 16.9: Joint sealant compatibility matrix

Before the material is specified by the designer, the designer should provide a technical specification to eliminate any possible risk of choosing an unfavourable and unsuitable adhesive.

The specification should include the following information:

- Which standard do they comply with
- Show proof of compliance
- Prescribed testing to be performed. *Field adhesion testing and maintenance inspections are recommended. There are several testing regimes noted on AS 1526*

Compared to mechanical joints such as rivets and screws, which can have relatively high local stress, an adhesive joint can carry load over larger areas. The strength, stiffness, energy absorption and durability of a correctly dimensioned adhesive joint will therefore be better. Uniform load distribution can also enable a reduction in material dimensions. In general, the advantages of adhesive bonding become more apparent when joining thin materials.

Other advantages include:

- Joints are continuous
- Single sided access
- Good fatigue properties
- Long life
- Clean finish without needing any holes or penetrations
- Sealing and joining in one step
- Render strong, stiff and impact resistant solution

The following factors should be considered before creating the said specification:

- Material type
- Application
- Surface treatment
- Service life
- Design of joints
- Mechanical properties and limitations
- Curing process

Fitness For Purpose

To be certified, the product(s) must be fit to perform its intended purpose or application.

The designer and applicant must ensure that the product is fit for its intended purpose.

The product must meet the performance requirements of relevant international standards for its intended application or be tested to relevant performance standards or equivalent.

Test reports for all relevant quality and performance tests showing that the product has been assessed by an external or internal laboratory testing.

Joint dimensioning

It is important for the designer to specify the correct dimension when doing the specification such as the size of the joints, which is to accommodate the expected movements (e.g., thermal expansion/compression) of the adjacent building elements and the movement capability of the selected sealant. It is also critical to take the differences in thermal expansion coefficients into consideration. Generally, the edges of the joints are usually being subjected to the greatest stresses.

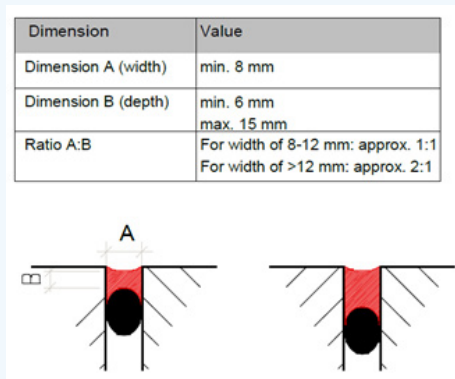

Figure 16.1: Examples of typical joint proportions

Site preparation

The key to a good sealant adhesion is ensuring a clean surface and substrate as this will directly impact the performance of the adhesive.

Non-porous substrates such as metals, coated surfaces (e.g. powder coatings) or plastics (e.g. PVC profiles) have to be degreased before applying. The correct cleaner is to be specified as the cleaner and other solvents can attack coatings. It is therefore recommended to perform tests on original substrates prior to use.

Many building materials such as cement board panels, concrete, granite, limestone and other stones or cement-based materials that absorb liquids are considered porous substrates. Dusting alone may be sufficient cleaning for new porous substrates. Depending on the condition of the surface, porous substrates may require abrasion steps in addition.

Elastic sealants should adhere to only two sides of the joint to perform properly. The bottom surface of the sealant must be free to deform. Often, if the bottom of sealant adheres, the sealant will rupture to deform. To avoid adhesion to the joint's bottom and to limit its depth backing rods are used.

It is recommended to use closed-cell polyethylene backing rods for joint sealing. To provide sufficient backpressure during sealant application, the backing rod should be sized ~25% larger than the joint width. Sizing differs among backing rod types and reference should always be made to the manufacturer's recommendations.

Standards

ISO 11600

This classification standard, issued by the International Organisation of Standardisation, specifies the types and classes of sealants used in building construction according to their applications and performance characteristics. It also describes the requirements and respective test methods for the different types and classes.

Area of application of the sealant:

- Type G for glazing sealants for use in glazing joints
- Type F for construction sealants for use in building joints others than glazing.

The movement capability and elastic behaviour of the sealant. The movement capability describes the ability of a joint sealant to expand and contract under load. ISO 11600 defines several tests regarding elongation, compression at different temperatures and environmental conditions.

EN 15651

EN 15651 is a mandatory approval for certain sealants sold within the European Union. The test methods are based on ISO 11600 and lead to CE marking. EN15651 defines requirements for the 5 following groups of sealants:

- EN15651-1 F: Sealants for façade elements
- EN15651-2 G: Sealants for glazing
- EN15651-3 S: Sealants for sanitary joints
- EN15651-4 P: Sealants for pedestrian walkways

The standards relevant to façades are discussed below:

EN 15651-1 Sealants for non-structural use in joints in buildings and pedestrian walkways - Part 1: Sealants for façade elements

EN 15651-1 deals with the definition and the requirements for non-structural façade sealants. The areas in which these joint sealants are used are:

- Outside of a building
- Window and door frames, including visible faces in indoor areas

Sealants for non-structural use in joints in buildings and pedestrian walkways - Part 2: Sealants for glazing

EN 15651-2 sets out definitions and requirements for non-structural, elastic joint sealants for sealing glazing in buildings. Included are glazing joints at an angle of 7° to the horizontal. The areas in which these joint sealants are used are:

- Glass to glass
- Glass to frames
- Glass to porous carrier materials

Further Education

The design of façades requires consideration of numerous factors and a broad knowledge of building physics. Aspiring façade engineers should seek to attend courses and read updates from associations which address the continuously changing requirements for the performance of façades.

University of Technology, Sydney

UTS: 49115 Façade Engineering – Engineering

The subject introduces students to the concepts and techniques involved in façade engineering and their application to the design and procurement of a building façade. The intent of encasing a building structure with a façade is to control the internal environment of the building, providing comfort to the occupants and allowing maximum natural light and ventilation into the building.

UTS: 11233 Advanced Architectural Construction - Design, Architecture and Building

This subject explores how the implementation of highly-integrated architectural spatial strategies, specific construction methods and material systems give rise to outstanding architectural outcomes.

Case studies focus on large-scale public and commercial building envelope systems. Students develop in-depth understanding of an existing envelope system and its inherent material and/or structural flaws. Through analysis of various parameters, students understand what causes the system to fail and therefore, what requires redesign. Students also consider how structural, material and environmental performance can create a framework of resilience, in line with design studio themes, and develop skills in parametric modelling.

Griffith University, Queensland

6108ENG Façade Engineering

This final year project-based course builds on the preceding civil and architectural courses and provides the basics of Façade Engineering with special emphasis on selection, analysis and design of façades including an understanding of the integral considerations of fabrication, construction, functionality and aesthetics in façade design.

Professional Networks

FAECF, Federation of the European Window and Curtain Wall Manufacturer Associations, UK

FAECF represents 15 national associations of the metal construction industry. The General Secretariat of FAECF is located in the Netherlands, the Technical Secretariat is located in Germany. The objective of FAECF is to strengthen and extend the position of the European fenestration industry in the market. It contributes essentially to European harmonization in fenestration and serves as an information centre for the public significance. European collaboration is increasingly gaining in. Many issues which were formerly addressed at the national level need to be reconsidered from an international point of view.

SFE, Society of Façade Engineering, UK

The Society of Façade Engineering was formed in 2004 as a joint initiative of CIBSE, IStructE and the RIBA. The Society of Façade Engineering brings these organisations together in a forum where they can work together to advance knowledge and practice in façade engineering, promote good practice and ensure that today's increasingly complex building façades meet the many and varying performance criteria. In particular, it addresses the complex issues in building physics of thermal insulation, ventilation, lighting, solar control, and acoustics.

Centre for Window and Cladding Technology (CWCT)

CWCT is located in the City of Bath and is a national and international resource. Events and courses are held in Bath, London and elsewhere in the U.K. Founded in 1989 it is now supported by over 350 member companies drawn from the broad spectrum of the industry, from clients and architects to contractors and manufacturers. Non-members are welcome to participate in CWCT courses and purchase CWCT publications.



Recommended Reading

The Fenestration And Cladding Engineering Technology Scheme [FACETS | CWCT](#)



Recommended Viewing

External Recommended Viewing Resources



Elemental Architectural Cladding Specialists: What is a rainscreen? – YouTube

Use of the Pattern Book



17

Chapter 17:

Use of the Pattern Book

The Pattern Book has been developed to serve as a guidance document for the designers participating in Project Remediate. It establishes the program specific requirements and provides background and rationale to some of those specifications.

It will serve as an educational tool for students of the façade industry. By raising the levels of knowledge and awareness of key issues at the grass roots, Project Remediate aims to make a positive contribution to the construction sector.

The Pattern Book includes a suite of details for each of the approved cladding materials and for each wall typology that is likely to be encountered. Solutions to common problems have been presented to streamline the design process.

This is a living document. Through the triage investigations and the design review process we will identify additional situations and solutions that should be incorporated into the Pattern Book and will update and augment the content on a regular basis. The Pattern Book is to be regarded as the repository of knowledge for the industry and all are welcome to contribute.

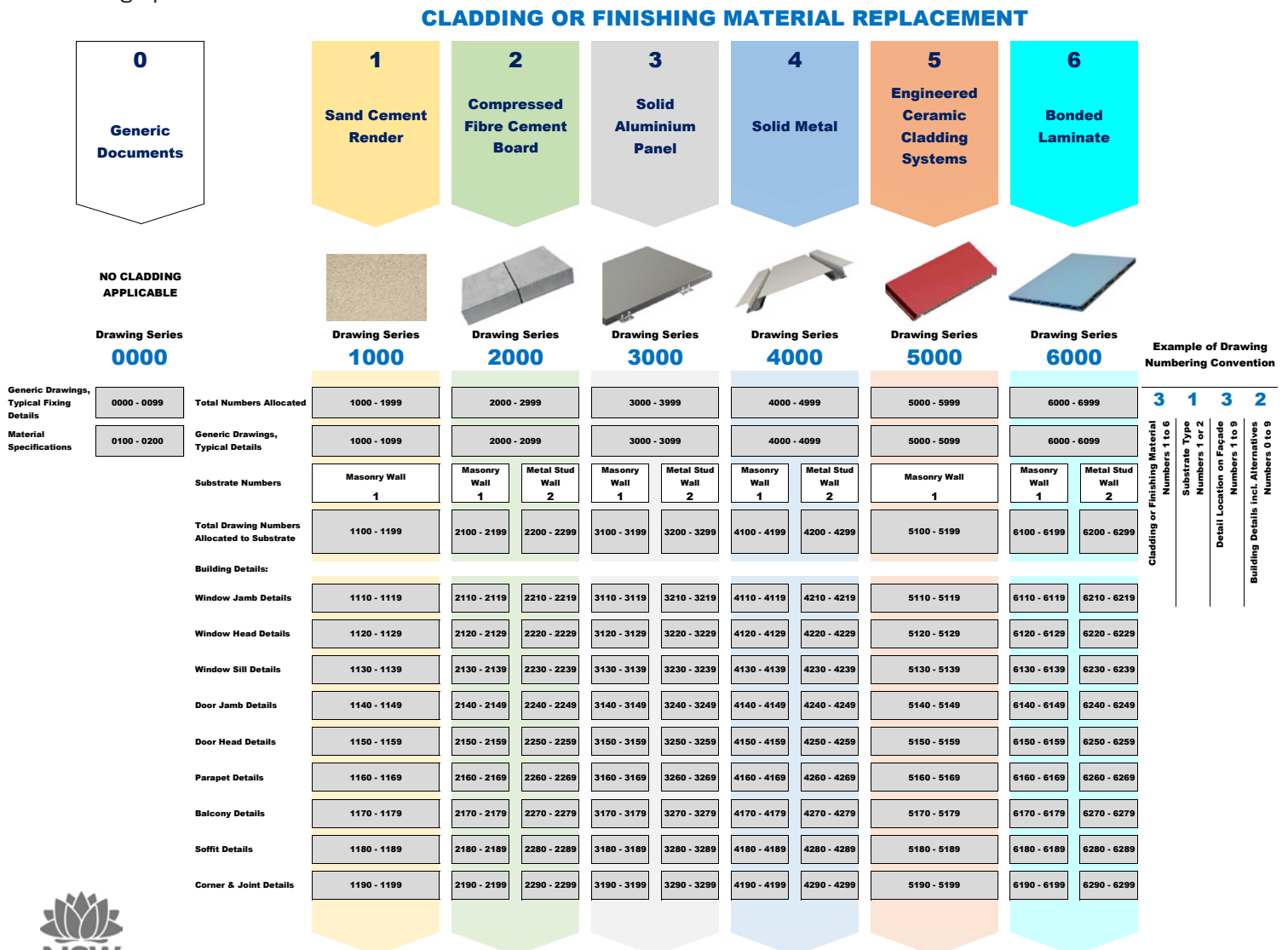

Figure 17.1: Drawing number navigation flowchart. Each drawing is given as a 4-digit number



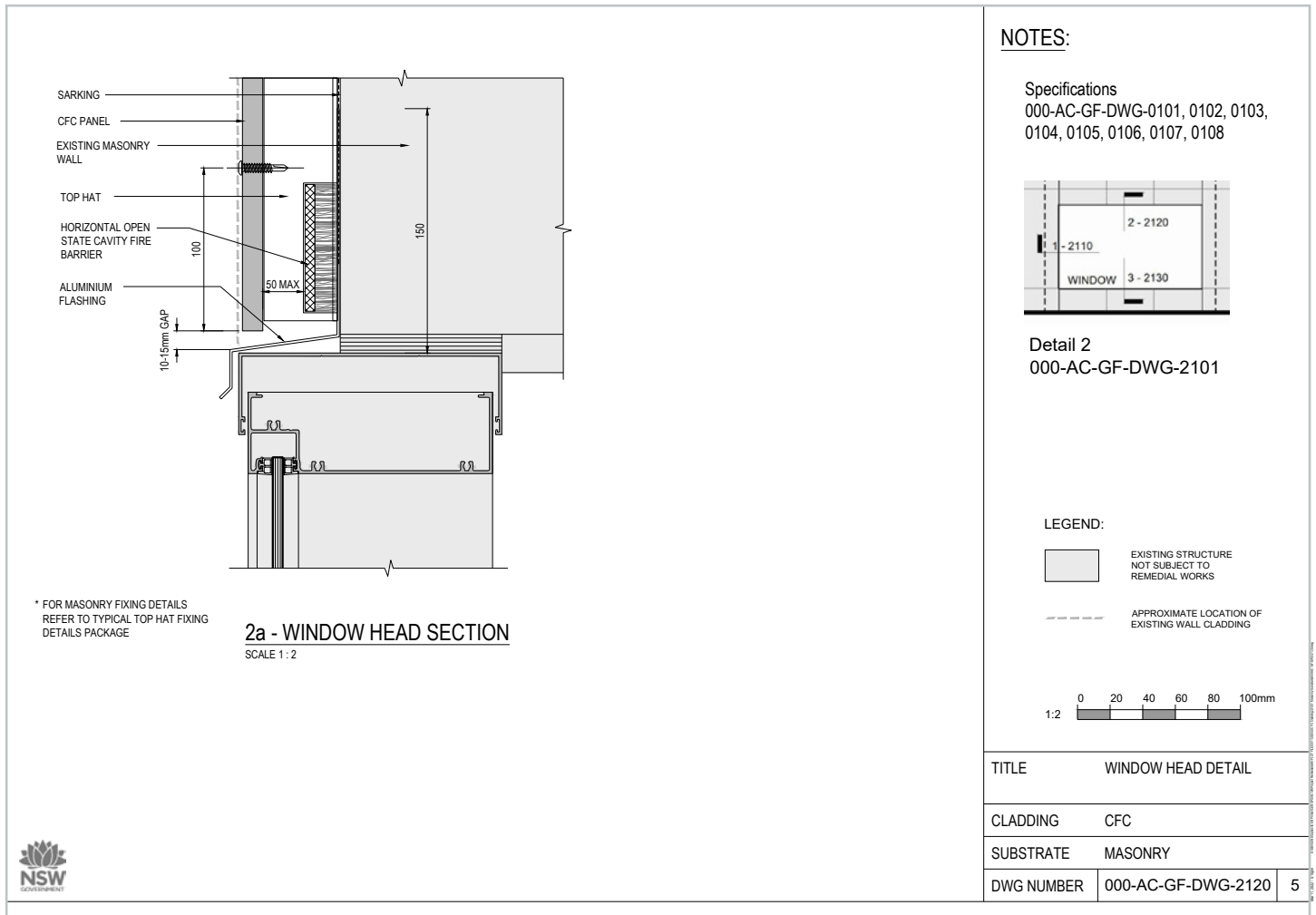

Figure 17.2: Example of drawing numbering

Navigating the Drawings

The drawings in the appendix are organised using a tiered approach which adopts a standardised detail numbering and drawing title reference convention, to allow the user to locate any detail as appropriate to the nominated material and the detail(s) of interest. Each drawing is given as a 4-digit number as shown in Figure 17.1.

The first number indicates the relevant cladding type:

- 1 = Non-combustible Cement Render
- 2 = Compressed Fibre Cement
- 3 = Solid Aluminium Panel
- 4 = Solid Metal Sheets
- 5 = Engineered Ceramic Cladding Systems (ECCS)
- 6 = Bonded Laminated Panel

These define a set of drawings which is applicable to that particular cladding.

Drawings which are applicable to all cladding types have “0” as the first digit. This includes:

- Fixings of subframes to backing walls
- Specifications for masonry anchors
- Specifications for wall membranes or “sarking”
- Specifications for fire barriers
- Specifications for sealants.

The second number identifies the backing wall or substrate:

- 1 = Masonry and Concrete
- 2 = Metal Framed wall

The remaining digits relate to specific locations where details are provided and are consistent across cladding types and backing walls.

For example, drawings with the numbers 2100 to 2199 provide details of Compressed Fibre Cement sheet cladding a masonry wall.

Evolution of details

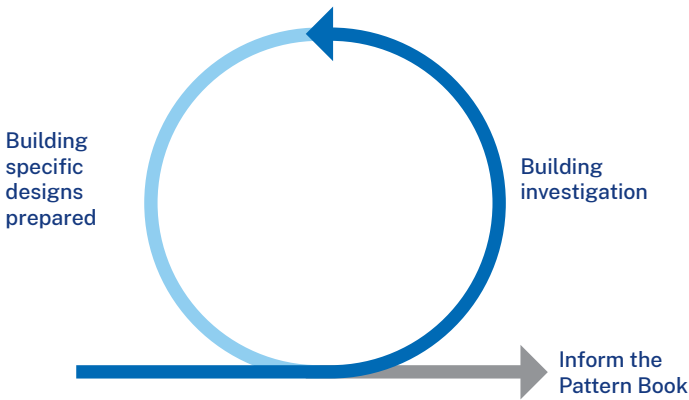

Figure 17.3: Evolution of details for the Pattern Book

Use of the Pattern Book in the recladding design

The below diagrams demonstrate a practical application of the Pattern Book to the Project Remediate. The Pattern Book plays a guidance role for the designers. It gives the designers step by step directions on investigations of existing structure, obtaining design input, making design decisions, developing cost base and developing architectural and engineering designs.

Project Remediate in a Nutshell

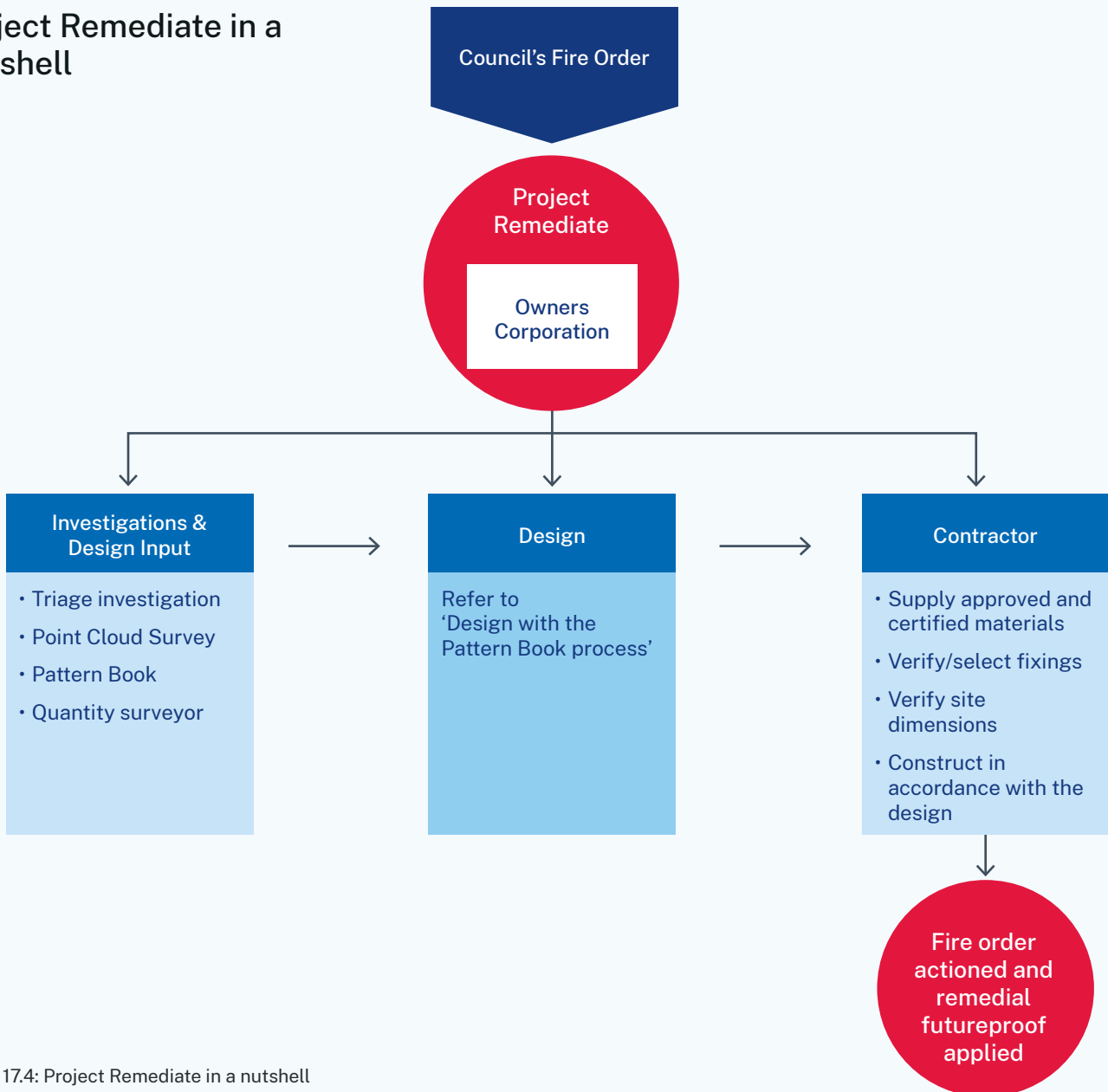

Figure 17.4: Project Remediate in a nutshell

Design with the Pattern Book process

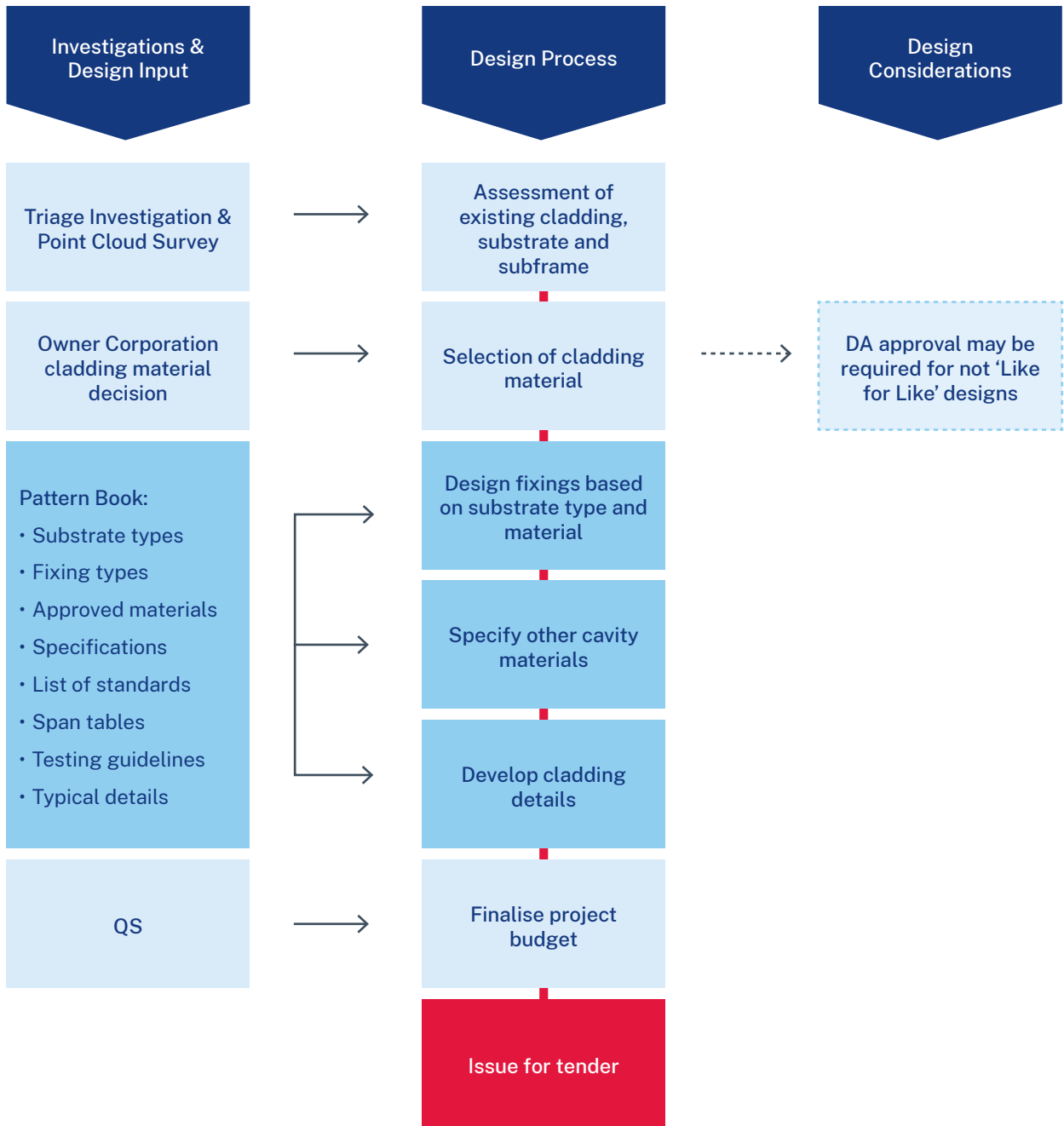

Figure 17.5: Design with the Pattern Book process

The Pattern Book is an evolving document and will be continually updated to incorporate details which may be useful for future designs.

Users of this book are encouraged to provide constructive feedback. Innovative design solutions are welcomed and will be added to the Pattern Book.

Design Responsibility and Disclaimer

Designs are to be site and project specific. Details and specifications in the Pattern Book are to be considered as a guide only for the purpose of minimising the design iterations which are undertaken to identify an optimal solution. Designers must verify all aspects of the details and undertake all necessary calculations to validate the engineering.

The Pattern Book is general advice only and it does not take into account the specific requirements and circumstances of any particular site or project. Designers, contractors and building owners will need to consider their own requirements and circumstances and obtain the appropriate advice on them and the contents of the Pattern Book before relying on the contents of the Pattern Book. The State of New South Wales accepts no responsibility or liability for any reliance on the contents of the Pattern Book.

Contributors

The program thanks all who have contributed to the Pattern Book. In particular the following companies have provided information or images which is included in this book:

- CSR
- Fairview
- Hilti
- Ignis Labs
- James Hardie
- MEL Consultants
- Mondoclad
- Panel Cycle
- TBA Firefly
- Tenmat
- Trafalgar Fire.

Case Studies



CASE STUDY 01



Figure 18.1: View of building (pre-construction)

Introduction

Case Study 01 is one of the first buildings delivered through Project Remediate. It is representative of many of the *Class 2* buildings in the program, and has highlighted a number of issues that Project Remediate has been sought to solve.

The subject building is a 3-storey structure comprising concrete floors a combination of concrete columns and load bearing walls. The external wall is generally composed of double cavity brick or block clad with bonded laminate panels.

A fire order was imposed which required the removal and replacement of approximately 310m² of combustible cladding.

Triage Investigations

An initial investigation was undertaken which involved removal of panels at key locations to identify the nature of the existing façade and structure. This identified that the cladding was supported through the bonding of flat, aluminium composite panels (ACP) to vertical top hats using silicone sealant. The top hats were in turn fixed to the wall using masonry nails.

The inspection recorded the depth of the cavity, general nature of the cladding at interfaces with windows and identified that the substrate varied from blockwork and brickwork.

Point Cloud Survey

A point cloud survey was undertaken which was imported into 3-dimensional modelling software to form the basis of the architectural and façade documentation.



Figure 18.2: Point Cloud data

Design

Two design options were initially considered and selected from the materials recommended by the CPSP, namely: solid aluminium and compressed fibre-cement sheet. Costings were undertaken which revealed the aluminium option to be marginally more cost effective for this situation. The Pattern Book details were used to inform the cost planner. Owners Corporation were presented with these options and selected solid aluminium as the preferred option.

While the external walls were found to be cavity brickwork, due to the poor nature of the mortar jointing in the masonry the design team elected to enhance the weatherproofing through the inclusion of suitably permeable sarking membranes.



Figure 18.3: Sarking complete with top hat subframe

The design proceeded using the Pattern Book recommended details and fixings. Cladding, support frames and substrate was modelled using Autodesk Revit modelling software with document control undertaken using BIM360

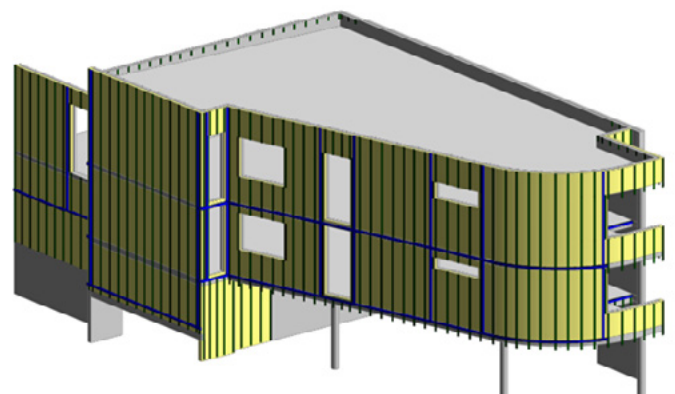

Figure 18.4: Isometric view of building model

CASE STUDY 01

Construction phase

On commencement of construction the cladding was removed which revealed a significant number of defects which could not have been identified through the triage sampling alone. This included the following:



Figure 18.5: Defective masonry construction



Figure 18.6: Timber lintels



Figure 18.7: Timber parapet framing

Rectification details were developed and submitted as Declared Designs. Generally, the construction progress followed the program, however, there was clearly a period when all parties involved learned to pivot from the commonly used design and construction approaches to recladding to the more rigorous design processes implemented by the *Design and Building Practitioners Act*.

In particular, the following issues arose:

- The design was based on the use of folded corners to aluminium panels. The contractor wished to implement routed corners which required a change to the design
- The specified masonry fasteners were not available when required and a substitution needed to be made.
- Alterations to flashing materials and dimensions were requested by the contractor

ESD Initiative

The recycling initiative developed by Project Remediate was implemented successfully with the following results:

3170kg was delivered to Panelcyle with this comprising both ACP panels top hats. These were subsequently recycled with no loss of materials through the separation process reported. It was also reported that 100% of the material was recovered/diverted from Landfill.

This project's recycling scheme resulted in the overall saving of approximately 13.96 tonnes of CO₂. This is the equivalent of removing 3.35 cars from our roads.

CASE STUDY 01



Figure 18.8: Sample of Materials to be Recycled



Figure 18.11: Removed materials in storage

Material	Quantity
Aluminium	0.665T
PE	0.074T
Aluminium	0.02T
Steel	1.35T
PE	1.061T
TOTAL	3.17T

Figure 18.9: Summary of Recycled Materials - by mass



Aluminium

Polyethylene

Figure 18.12: Materials in final recycled form

Waste Breakdown

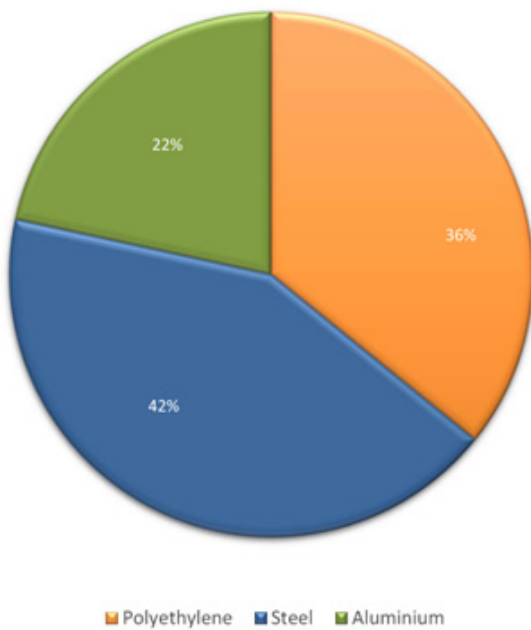

Figure 18.10: Waste Breakdown

The savings in landfill space due to the recycling of materials equated to 31.91m³ which equates to approximately 132.97 wheelie bins.

CASE STUDY 01

Key Lessons

- The triage investigations are a highly valuable stage in the reclad process to inform the extent of the proposed works and identify the existing conditions. They cannot verify all latent conditions to be encountered during construction process without excessive disruption to occupants and incurring considerable costs to the Owners as a result. A process during construction of cladding removal and substrate identification needs to be embedded into the construction program with sufficient time allowed for to develop suitable designs.
- The quality of existing construction should not be over estimated. Through this and other buildings examined in the Programme, there appears to be a legacy of poor quality design and construction of Class 2 buildings in NSW.
- The *Design and Buildings Practitioners (DBP) Act* imposes obligations on the *Design Practitioners* to ensure their documentation reflects the information reasonably obtainable prior to construction. Upgrading of documentation can often be unavoidable when dealing with remediation projects without excessive investigatory works. It is important for both *Design Practitioners* and *Building Practitioners* to not only be aware of their obligations under this Act, but to also be aware of the practicalities of maintaining such obligations whilst construction activity is ongoing. A direct and effective line of communication between the Building Practitioner and the Design Practitioner is advantageous.
- Latent conditions often present unforeseen challenges. The *DBP Act* stipulates that *Design and Building Practitioners* must certify the new works are compliant under the National Construction Code (NCC), and, consequently identified latent conditions must be reviewed and subsequent action taken where necessary. The project should consider the impact of such unforeseen challenges in advance such that a strategy can be developed to respond accordingly and efficiently.
- Whilst the *Program* is limited to its defined scope, it is important that Owners are effectively engaged such as to raise awareness of latent defects identified which may require action as part of future rectification works. Future works can therefore be allowed for within the replacement cladding' design through bespoke detailing measures accordingly.
- It is critical that the *Owners Corporations* are clearly advised on the scope of works which are included as part of the *Program*. Scope creep must be managed by the Superintendent.
- Design details must be agreed with the contractor prior to commencement on site to allow the design of any proposed enhancements or alternatives to be completed and declared.
- Availability of materials and components must be confirmed prior to commencing work as any substitutions must be subject to appropriate scrutiny and updated on the design documentation.
- The project demonstrated that much of the products removed from a reclad project can be successfully and economically recycled.



Figure 18.13: View of building (post-remediation works)

Definitions

C

- Cavity Barrier** Cavity barriers are typically pieces of fire-stopping material which are fitted within building façade cavities -horizontally at each floor, around window and door openings and vertically at each party wall. Cavity barriers are essential to restrict the spread of smoke or flames. If there is a fire, the intumescent material which makes up the horizontal barrier will expand, sealing off the gaps.
- Cladding** The term ‘cladding’ refers to components that are attached to the primary structure of a building to form non-structural, external surfaces. This is as opposed to buildings in which the external surfaces are formed by structural elements, such as masonry walls, or applied surfaces such as render.
- Composite** In the context of cladding, composite refers to cladding materials which comprise multiple materials which act together (compositely) during service.
- Condensation** Condensation is the conversion of a vapour to a liquid. Vapour in a form of water droplets collects on a cold surface when humid air is in contact with it.

D

- Dew Point** When air cools, it is less able to “hold” moisture, that is, the saturation water vapour density falls, and so relative humidity rises. When the relative humidity reaches 100%, the air will be saturated. This is described as the ‘dew point’ temperature, or the ‘saturation temperature’. If the air continues to cool, moisture will begin to condense. Where this condensate forms on a surface, it can be described as ‘dew’, hence the term ‘dew point’.
- Understanding this phenomena is important in the design and construction of new buildings, and in the assessment of existing buildings, as the formation of condensation can be damaging, can affect comfort and can be a hazard to health.
- Durability** Durability is the resistance to degradation of products, materials, buildings and other built assets over time. This can be a difficult property to assess -whilst a tough material may be hard to the touch, it may also be non-durable if it decomposes or is eroded in a relatively short period of time. The opposite can also be true.

F

- Fire Resistance of Buildings** The ability of a component or a building to satisfy, for a stated period of time, some or all of the appropriate criteria given in the relevant standard.
- Fire resistance is a measure of one or more of the following:
- Resistance to collapse (loadbearing capacity), which applies to loadbearing elements only
 - Resistance to fire penetration (integrity)
 - Resistance to the transfer of excessive heat (insulation)
- Fire resistance is measured in minutes. This relates to time elapsed in a standard test and should not be confused with real time.
- The fire resistance level (FRL) is typically specified by listing the associated fire ratings for each of the above components -namely: structure, integrity and insulation. Where 60-minutes fire resistance is provided for each, the FRL would be represented by 60/60/60.

P

- Packers** Solid materials in the form of plates or similar and used between two connected materials/ elements to allow construction tolerances to be accommodated without adversely affecting the setting-out of connected materials/elements. The material used in this program must be non-combustible as defined in accordance with AS 1530.1.

Pressure equalised (PE) system A cladding system which allows the wind to blow behind the external rainscreen cladding which in turn equalises the pressure either side of it. This principle ensures there is no differential air pressure between the external zone and the cavity, and is critical in developing an effective rainscreen solution. This largely prevents rain driving in through the joints in the cladding.

R

R-value R-values are a measure of the thermal resistance of a material of a specific thickness, that is, its resistance to the transfer of heat across it. The higher the R-value of a material, the more effective it is as an insulator.

Relative Humidity (RH) Relative humidity (RH) is a measure of the water vapour density of air compared to the water vapour density for saturated air at the same temperature and pressure (that is, the maximum amount of moisture that air can “hold” at that temperature and pressure). It is expressed as a percentage.

$$\text{RH} = (\text{actual water vapour density} / \text{saturation water vapour density}) \times 100$$

Rainscreen A rainscreen (sometimes referred to as a ‘drained and ventilated’ or ‘pressure-equalised’ façade) is an exterior wall detail where the wall cladding stands off from the moisture-resistant surface of an air/water barrier applied to the sheathing to create a capillary break and to allow drainage and evaporation.

S

Sarking (Breather Membrane) Breather membranes (or breathable membranes) are water resistant but vapour permeable. Typically, they are used within external wall and roof constructions where the external cladding may not be completely water-tight or moisture resistant, such as in tiled roofs or framed wall constructions.

Self-Tapping Screw A self-tapping screw is a screw that can tap its own hole as it is driven into the material. More narrowly, self-tapping is used only to describe a specific type of thread-cutting screw intended to produce a thread in relatively soft material or sheet materials, excluding wood screws. Other specific types of self-tapping screw include self-drilling screws and thread rolling screws.

Subframe A metal frame that supports rainscreen façade cladding. It is located within the ventilated wall cavity and is mechanically fixed to the wall substrate. Different rainscreen systems use their own, sometimes unique, fixing elements and methods. Commonly, main subframe elements are made of a galvanized steel. In areas with a high content of moisture in the air, it is advisable to use stainless steel or aluminium subframe elements to increase the lifespan of the cladding.

Substrate Wall element which already meets the necessary air tightness and mechanical strength requirements. There are several types of substrates/walls. These are masonry walls, concrete walls and metal frame walls.

Courtesy:

Designing Buildings, The Construction WIKI

<https://www.designingbuildings.co.uk/>

Office of Project Remediate

NSW Department of Customer Service
McKell Building, 2-24 Rawson Place
Haymarket NSW 2001

E: projectremediate@customerservice.nsw.gov.au

W: nsw.gov.au/project-remediate

